

CONTENTS

Profile	011 ~ 055
Angle	056 ~ 062
Duct	063 ~ 070
Conveyor Frame	071 ~ 088
Profile Accessory	089 ~ 138
Air Supply System	139 ~ 143
AL Tube	144 ~ 148
Technical Data	149 ~ 151

DYC introduction



국내 산업용 AL 제품의 선두주자인 당사는 다양하고 간편하게 조립이 가능한 높은 품질의 AL Frame을 개발하여, 국내 산업발전에 획기적인 전기를 마련하였습니다.

DYC Frame은 용도에 맞게 다방면으로 사용이 가능한 구조용 System, 독자적인 T홈 구조로 각종 부속품을 임의의 위치에 취부 가능하고, 아울러 언제든지 변경이 가능합니다.

그리고 그 다양한 용도는 앞서서도 거론했지만 Machine Cover Frame, Conveyor Frame 등 각종 구조물용으로 다양하게 사용하실 수가 있습니다.

그리고 당사에서는 이에 만족하지 않고, 선진 외국의 제품에 조금도 뒤지지 않는 품질의 제품을 생산하기 위해서 끊임없이 개선하고 개발하는데 최선을 다하고 있습니다.

DAE YEONG Metal, a forerunner of aluminum products of local industry, has high quality aluminum frames which are diverse and easy-to-be-assembled, and thus provided an epoch-making turning point for domestic industry.

The DYC Frames can be applied flexibly to diverse conditions, and their independent structure of slots allows for almost every component. Thus, the Frame will be used in diverse forms for machine cover and conveyor.

You should be assured of our continued efforts to produce higher quality products which cannot fall behind those of advanced country

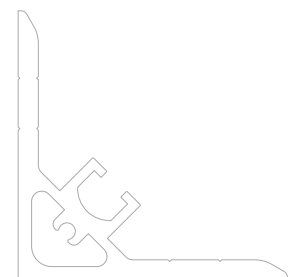
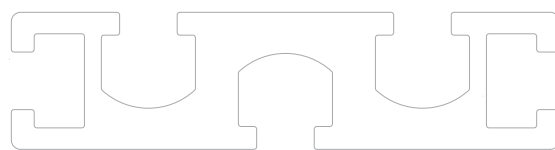
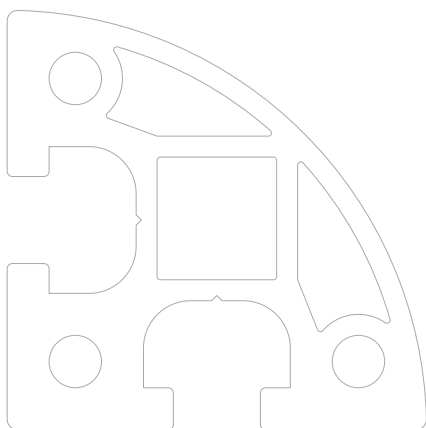
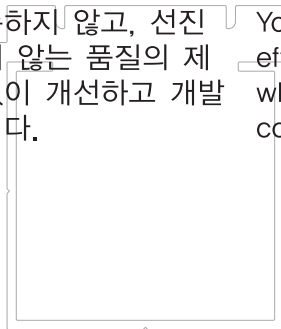

변경이 간편하고 경량이면서도 견고성을 자랑하는

DYC AL FRAME

DYC AL PROFILE은

T홈 구조의 Frame과 조립시에 필요한 각종 Element와 Bracket으로 구성되어 있습니다.

왜 DYC Frame인가?

- 가볍고 내구성이 뛰어나다.
- 깨끗하고 미려한 외관이다.
- 도장이 필요없다.

왜 T홈인가?

- 용접이 필요없다.
- 절단만으로 모든 가공이 완료
- 간단하고 빠른 조립으로 많은 시간과 인원 절약
- 설계가 간단하다.
- 재료 구입의 합리화(소량구입 가능)
- 제작기간의 단축
- 치수변경이 간편
- 작업장의 쾌적화
- Part의 재활용
- 단 납기의 실현

각종 Frame으로 사용가능

Frame을 비롯하여 Bracket등 각종 Element를 DYC Series를 사용하면 기계가공부품과 시간, 인원을 대폭 줄일 수 있습니다.

NO.	DYC Frame	Steel
설 계	간단한 도면	복잡한 도면
제 작	① 재료절단 ② 조립	① 재료절단
		② 용접
		③ 기계가공
		④ 후가공
도 장	불필요 (영구적)	필요 (일정한 기간마다 계속필요)
외 관	쾌적한 환경조성	기계적인 환경조성

















각종용도



















Conveyor Frame 조립기, 검사장비, 파렛트 교환기, 작업대, 각종대차, 각종 전용기 Cover등



















- DYC Frame과 각종 Element의 적용범위를 조금만 생각해 보시면 위의 용도 외에도 그 사용 범위가 어디에서든지 보다 광범위하게 사용 할 수 있다는 점을 느낄 수 있을 것입니다.
- 각종 Cover취부용 구조물로 사용가능
DYC Frame으로 Box를 조립하여 Cover취부용 Bracket으로 조립하면 강판이나 아크릴판 등으로 자유롭게 Cover취부가 가능합니다.











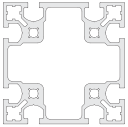

















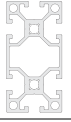
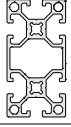

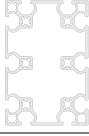
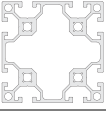
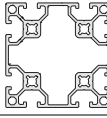















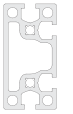
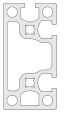

DYC의 PROFILE SYSTEM은 고객 여러분의 생산성 향상 및 비용절감을 추구합니다.

SUMMARY















	15 X 30	15 X 60	15 X 90	20 X 20	20 X 40	30 X 30	30 X 40	30 X 60
cad								
Item NO.	DF 1530	DF 1560	DF 1590	DF 2020	DF 2040	DF 3030	DF 3040	DF 3060
Material	A6063-T5	A6063-T5	A6063-T5	A6063-T5	A6063-T5	A6063-T5	A6063-T5	A6063-T5
Weight	0.65kg/m	1.3kg/m	2.023kg/m	0.39kg/m	0.727kg/m	1.073kg/m	0.882kg/m	1.797kg/m
T Groove								
Page	12	12	13	13	14'	14'	15	15







	30 X 90	30 X 120	35 X 35	35 X 70	40 X 40	40 X 80	40 X 120	40 X 160	45 X 45
									
	DF 3090	DF 30120	DF 3535	DF 3570	DF 4040	DF 4080	DF 40120	DF 40160	DF 4545
	A6063-T5	A6063-T5	A6063-T5	A6063-T5	A6063-T5	A6063-T5	A6063-T5	A6063-T5	A6063-T5
	2.543kg/m	3.279kg/m	1.515kg/m	2.493kg/m	1.909kg/m	3.391kg/m	4.553kg/m	5.837kg/m	2.192kg/m
									
	16	16	17	17	18	18	19	19	20



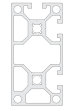
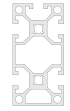
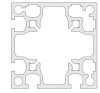
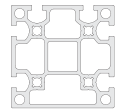
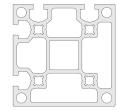
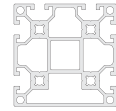







	45 X 60	45 X 90	50 X 50	60 X 60	60 X 90	60 X 120	80 X 80	80 X 120	80 X 160
									
	DF 4560	DF 4590	DF 5050	DF 6060	DF 6090	DF 60120	DF 8080	DF 80120	DF 80160
	A6063-T5	A6063-T5	A6063-T5	A6063-T5	A6063-T5	A6063-T5	A6063-T5	A6063-T5	A6063-T5
	2.257kg/m	3.758kg/m	3.009kg/m	2.718kg/m	3.385kg/m	4.673kg/m	5.238kg/m	6.863kg/m	9.227kg/m
									
	20	21	21	22	22	23	23	24	24











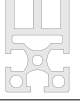























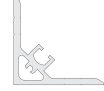

90 X 90	66 X 30	88 X 40	60 X 60	30 X 30	30 X 60	30 X 90	30 X 120	40 X 40
								
DF 9090	DF 6630	DF 8840	DFR 6060	DNF 3030	DNF 3060	DNF 3090	DNF 30120	DNF 4040
A6063-T5	A6063-T5	A6063-T5	A6063-T5	A6063-T5	A6063-T5	A6063-T5	A6063-T5	A6063-T5
5.862kg/m	2.179kg/m	4.01kg/m	2.094kg/m	0.85kg/m	1.451kg/m	2.118kg/m	2.847kg/m	1.68kg/m
								
25	25	26	26	27	27	28	28	29
40 X 40	40 X 80	40 X 80	60 X 60	60 X 90	80 X 80	80 X 80	20 X 40	40 X 80
								
DNF 4040B	DNF 4080	DNF 4080B	DNF 6060	DNF 6090	DNF 8080	DNF 8080B	DHF 4040	DHF 4080
A6063-T5	A6063-T5	A6063-T5	A6063-T5	A6063-T5	A6063-T5	A6063-T5	A6063-T5	A6063-T5
1.58kg/m	2.729kg/m	2.631kg/m	2.226kg/m	3.195kg/m	4.37kg/m	4.009kg/m	2.364kg/m	4.03kg/m
								
29	30	30	31	31	32	32	33	33
20 X 20	20 X 40	30 X 30	30 X 30	30 X 60	30 X 60	30 X 60	30 X 60	30 X 60
								
DCF 2020-1	DCF 2040-1	DCF 3030-1	DCF 3030-2	DCF 3030-3	DCF 3060-1	DCF 3060-2	SDNF 3060-S1	SDNF 3060-1
A6063-T5	A6063-T5	A6063-T5	A6063-T5	A6063-T5	A6063-T5	A6063-T5	A6063-T5	A6063-T5
0.396kg/m	0.752kg/m	1.086kg/m	1.104kg/m	1.248kg/m	1.844kg/m	1.874kg/m	1.612kg/m	1.527kg/m
								
34	34	35	35	36	36	37	37	38

SUMMARY

















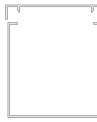





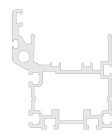
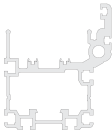
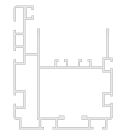

	40 X 40	40 X 40	40 X 40	40 X 40	40 X 40	40 X 80	40 X 80	40 X 80
cad								
Item NO.	DCF 4040-1	DCF 4040-2	DCFNF 4040-1	DCFNF 4040-2	DCFNF 4040-L2	DCF 4080-1	DCF 4080-L2	DCF 4080-2
Material	A6063-T5	A6063-T5	A6063-T5	A6063-T5	A6063-T5	A6063-T5	A6063-T5	A6063-T5
Weight	1.952kg/m	1.924kg/m	1.687kg/m	1.693kg/m	1.685kg/m	3.321kg/m	3.423kg/m	3.402kg/m
T Groove								
Page	38	39	39	40	40	41	41	42









40 X 80	40 X 80	30 X 60	40 X 80	60 X 60	60 X 60	80 X 80	80 X 80	80 X 80
								
DCNF 4080-1	DCNF 4080-2	DCNF 4080-L1	DCNF 4080-L2	DCF 6060-1	DCF 6060-2	DCF 8080-1	DCF 8080-2	DCNF 8080-1
A6063-T5	A6063-T5	A6063-T5	A6063-T5	A6063-T5	A6063-T5	A6063-T5	A6063-T5	A6063-T5
2.729kg/m	2.817kg/m	2.718kg/m	2.618kg/m	2.705kg/m	2.752kg/m	5.329kg/m	5.254kg/m	5.014kg/m
								
42	43	43	44	44	45	45	46	46

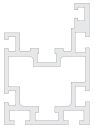
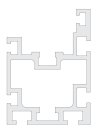

80 X 80	20 X 20	30 X 30	40 X 40	60 X 60	80 X 80	30 X 23	40 X 23	20 X 30
								
DCNF 8080-2	DRF 2020	DRF 3030	DRF 4040	DRF 6060	DRF 8080	GF 3023	GF 4023	RF 2030
A6063-T5	A6063-T5	A6063-T5	A6063-T5	A6063-T5	A6063-T5	A6063-T5	A6063-T5	A6063-T5
4.944kg/m	0.356kg/m	0.936kg/m	1.739kg/m	2.537kg/m	4.694kg/m	1.011kg/m	1.391kg/m	0.581kg/m
								
47	47	48	48	49	49	50	50	51

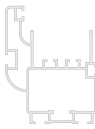
30 X 45	40 X 55	9 X 32	15 X 30	20 X 30	20 X 30	20 X 35	20 X 40	20 X 35
								
RF 3045	RF4055	DY 1483	DY 3942	DY 3399	DY 3730	DY 1476	DY 1477	DY 1723
A6063-T5	A6063-T5	A6063-T5	A6063-T5	A6063-T5	A6063-T5	A6063-T5	A6063-T5	A6063-T5
1.630kg/m	2.391kg/m	0.328kg/m	0.303kg/m	0.620kg/m	0.308kg/m	0.771kg/m	0.960kg/m	0.802kg/m
								
51	52	52	53	53	54	54	55	55
20 X 20	30 X 30	40 X 40	60 X 45	60 X 60	60 X 135	60 X 30	60 X 150	80 X 80
								
DAB 2020	DAB 3030	DAB 4040	DAB 6045	DAB 6060	DAB 60135	DAB 6030	DAB 60150	DAB 8080
A6063-T5	A6063-T5	A6063-T5	A6063-T5	A6063-T5	A6063-T5	A6063-T5	A6063-T5	A6063-T5
0.294kg/m	0.727kg/m	0.988kg/m	1.635kg/m	1.956kg/m	2.111kg/m	2.401kg/m	2.152kg/m	2.981kg/m
58	58	58	59	59	59	60	60	60
30 X 90	40 X 120	60 X 120	80 X 160	5 X 60	30 X 60	31 X 60	40 X 90	40 X 40
								
DAF 3090	DAF 40120	DAF 60120	DAF 80160	DJF 1060	DAD 3060	DAD 3160	DAD 4090	DAD 4040
A6063-T5	A6063-T5	A6063-T5	A6063-T5	A6063-T5	A6063-T5	A6063-T5	A6063-T5	A6063-T5
1.269kg/m	1.962kg/m	1.674kg/m	2.589kg/m	0.812kg/m	1.084kg/m	0.991kg/m	1.810kg/m	C:0.420kg/m B:0.670kg/m
61	61	61	62	62	64	64	65	65

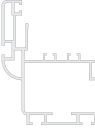
SUMMARY

	40 X 80	45 X 45	60 X 60	80 X 45	80 X 80	80 X 80	100 X 100	105 X 50	
cad									
Item NO.	DAD 4080	DAD 4545	DAD 6060	DAD 8045	DAD 8080	DAD 8080-1	DAD 100100	DAD 10550	
Material	A6063-T5	A6063-T5	A6063-T5	A6063-T5	A6063-T5	A6063-T5	A6063-T5	A6063-T5	
Weight	C:0.635kg/m B:0.886kg/m	C:0.348kg/m B:0.728kg/m	C:1.016kg/m B:0.484kg/m	C:0.582kg/m B:0.992kg/m	C:0.601kg/m B:1.360kg/m	C:0.635kg/m B:1.316kg/m	C:0.776kg/m B:1.691kg/m	C:0.776kg/m B:1.149kg/m	
T Groove									
Page	66	66	67	67	68	68	69	69	
	150 X 80	53 X 26	110 X 28	110 X 50	141 X 120	141 X 120	125 X 100	145 X 118	25 X 90
									
	DAD 15080	DC 5326	DC 11028	DC 11050	DC 1612	DC 1005	DC 1006	DC 1024	DC 2590
	A6063-T5	A6063-T5	A6063-T5	A6063-T5	A6063-T5	A6063-T5	A6063-T5	A6063-T5	A6063-T5
	C:0.918kg/m B:1.681kg/m	2.246kg/m	4.151kg/m	5.553kg/m	7.823kg/m	7.981kg/m	4.062kg/m	10.072kg/m	1.506kg/m
	70	72	72	73	73	74	74	75	75
	25 X 130	33 X 90	40 X 24	40 X 73	43 X 122	45 X 70	30 X 45	45 X 75	62 X 18
									
	DC 25130	DC 3390	DC 4024	DC 4073	DC 43122	DC 4570	DC 3045	DC 4575	DC 6218
	A6063-T5	A6063-T5	A6063-T5	A6063-T5	A6063-T5	A6063-T5	A6063-T5	A6063-T5	A6063-T5
	2.483kg/m	2.574kg/m	1.029kg/m	4.011kg/m	4.027kg/m	2.675kg/m	1.389kg/m	3.035kg/m	1.270kg/m
	76	76	77	77	78	78	79	79	80

63 X 90	65 X 90	66 X 30	76 X 45	80 X 100	85 X 110	100 X 80	100 X 125	103 X 48
								
DC 6390	DC 6590	DC 6630	DC 7645	DC 80100	DC 85110	DC 10080	DC 100125	DC 10348
A6063-T5	A6063-T5	A6063-T5	A6063-T5	A6063-T5	A6063-T5	A6063-T5	A6063-T5	A6063-T5
3.702kg/m	3.797kg/m	1.556kg/m	2.580kg/m	5.667kg/m	3.081kg/m	5.659kg/m	4.174kg/m	3.358kg/m

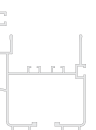
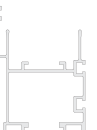
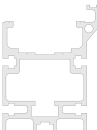
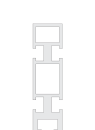
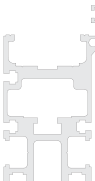
80	81	81	82	82	83	83	84	84
121 X 90	125 X 100	100 X 125	125 X 100	80 X 136	20 X 75	80 X 166		
								
DC 12190	DC 125100	DY 1145	DY 1031	DY 1054	DY 1248	DY 1886		
A6063-T5	A6063-T5	A6063-T5	A6063-T5	A6063-T5	A6063-T5	A6063-T5		
5.038kg/m	3.218kg/m	3.468kg/m	4.516kg/m	6.974kg/m	1.646kg/m	10.604kg/m		

85	85	86	86	87	87	88
----	----	----	----	----	----	----

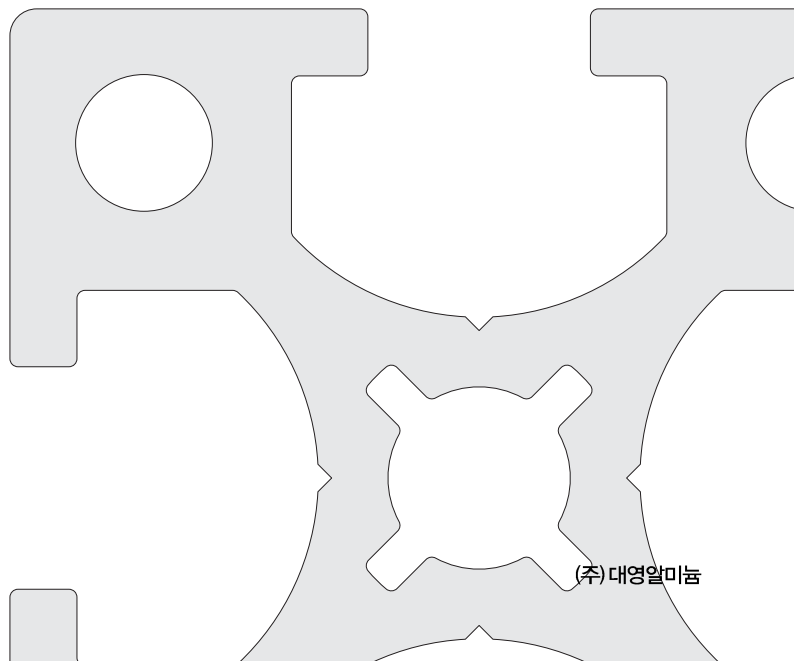

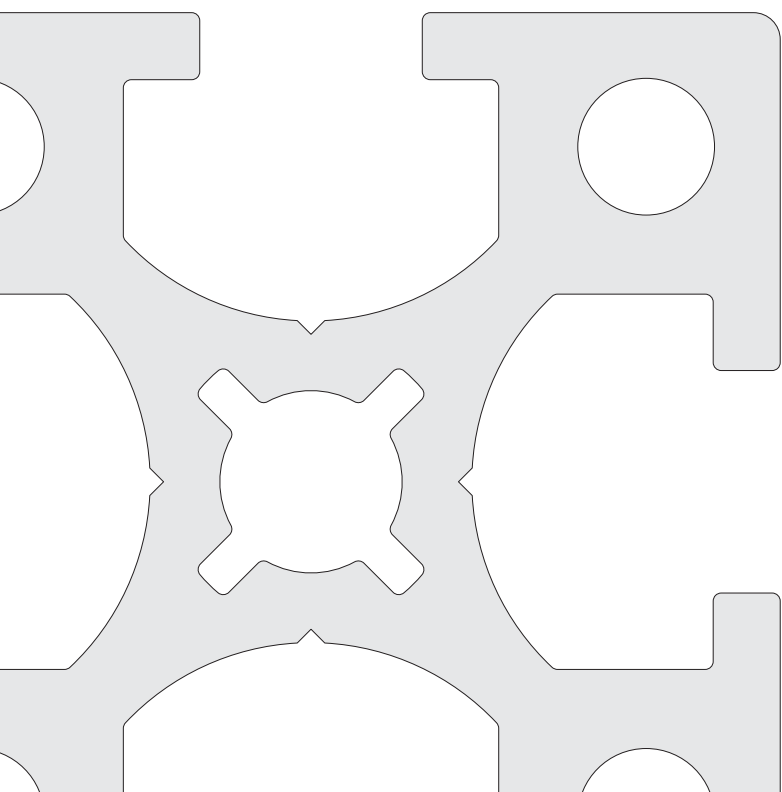

PROFILE

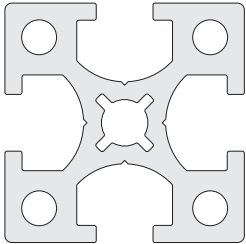

PROFILE



DF 1530 15 X 30

ORDER NUMBER **DY 5001**



Technical Data (技術 Data)

Material (材質)	A6063-T5
Surface Processing (表面處理)	Anodized
Weight (重量)	0.65kg/m
Section Area (斷面積)	239.8562mm ²
Second Section Moment (斷面2次 Moment)	lx=0.7x10cm ⁴ ly=1.5x10cm ⁴
Specification (仕様)	4,000mm / 6,000mm
Color (色相)	Silver, Black
Application (用途)	Machine Structure Frame, Work Table, Machine Cover, Door&Windows Frame, Sensor Bracket <small>(기계구조물, 작업대, 기계커버, 기계창문 및 문 센서 브라켓)</small>

CAD Drawing

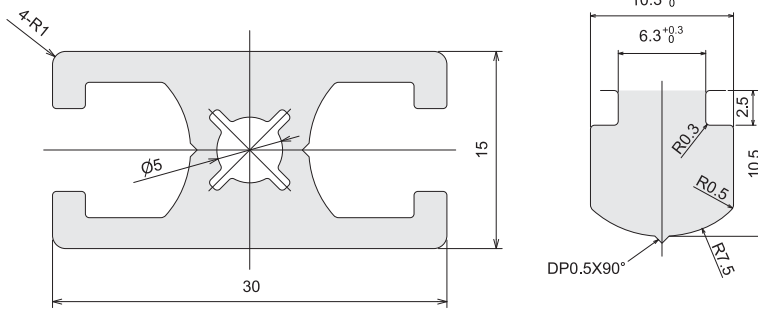

PROFILE



DF 1560 15 X 60

ORDER NUMBER **DY 5002**

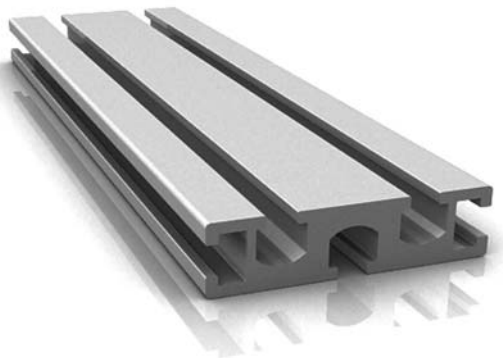

Technical Data (技術 Data)

Material (材質)	A6063-T5
Surface Processing (表面處理)	Anodized
Weight (重量)	1.3kg/m
Section Area (斷面積)	479.5255mm ²
Second Section Moment (斷面2次 Moment)	lx=1.2x10cm ⁴ ly=13.0x10cm ⁴
Specification (仕様)	4,000mm / 6,000mm
Color (色相)	Silver, Black
Application (用途)	Machine Structure Frame, Work Table, Machine Cover Door & Windows Frame, Sensor Bracket <small>(기계구조물, 작업대, 기계커버, 기계창문 및 문 센서 브라켓)</small>

CAD Drawing

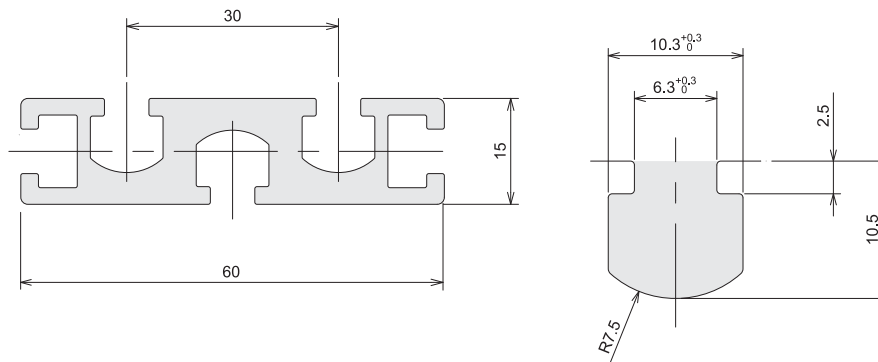

PROFILE



DF 1590 15 X 90

ORDER NUMBER **DY 5003**

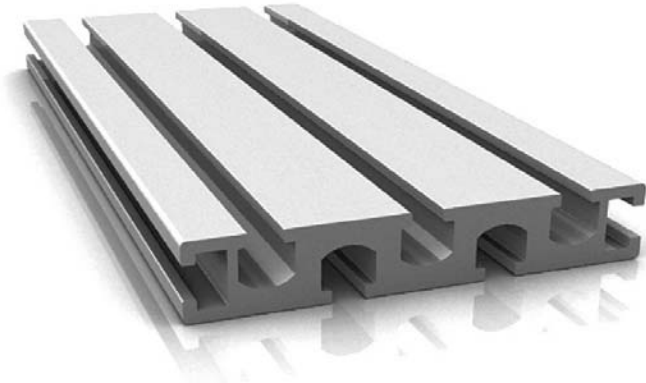

Technical Data (技術 Data)

Material (材質)	A6063-T5
Surface Processing (表面處理)	Anodized
Weight (重量)	2.023kg/m
Section Area (斷面積)	746.3982mm ²
Second Section Monent (斷面2次 Moment)	lx=1.8x10cm ⁴ ly=46.0x10cm ⁴
Specification (仕様)	4,000mm / 6,000mm
Color (色相)	Silver, Black
Application (用途)	Machine Structure Frame, Work Table, Machine Cover (기계구조물, 작업대, 기계커버)

CAD Drawing

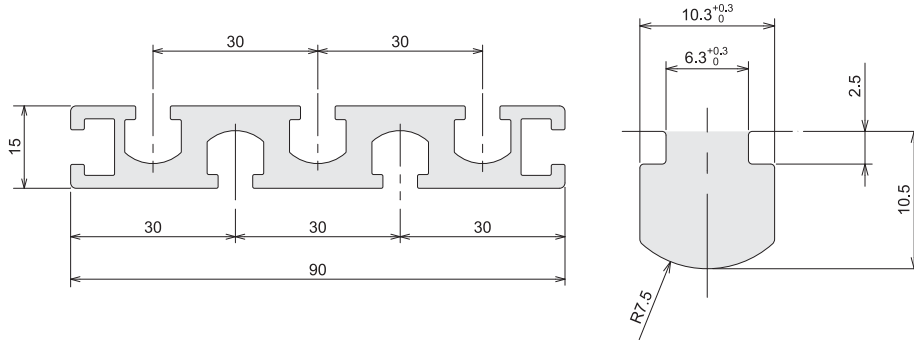

PROFILE



DF 2020 20 X 20

ORDER NUMBER **DY 5004**



Technical Data (技術 Data)

Material (材質)	A6063-T5
Surface Processing (表面處理)	Anodized
Weight (重量)	0.39kg/m
Section Area (斷面積)	143.9481mm ²
Second Section Monent (斷面2次 Moment)	lx=0.59x10cm ⁴ ly=0.59x10cm ⁴
Specification (仕様)	4,000mm / 6,000mm
Color (色相)	Silver, Black
Application (用途)	Machine Structure Frame, Work Table, Machine Cover (기계구조물, 작업대, 기계커버)

CAD Drawing

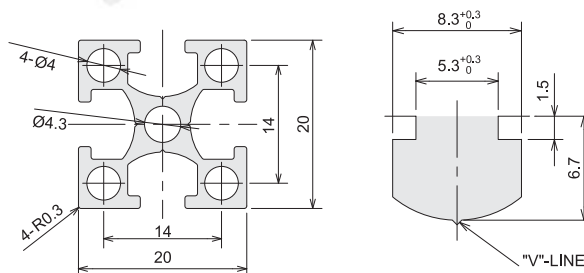

PROFILE



DF 2040 20 X 40

ORDER NUMBER **DY 5005**



Technical Data (技術 Data)

Material (材質)	A6063-T5
Surface Processing (表面處理)	Anodized
Weight (重量)	0.727kg/m
Section Area (斷面積)	268.1923mm ²
Second Section Moment (斷面2次 Moment)	lx=1.1x10cm ⁴ ly=4.2x10cm ⁴
Specification (仕様)	4,000mm / 6,000mm
Color (色相)	Silver, Black
Application (用途)	Machine Structure Frame, Work Table, Machine Cover (기계구조물, 작업대, 기계커버)

CAD Drawing

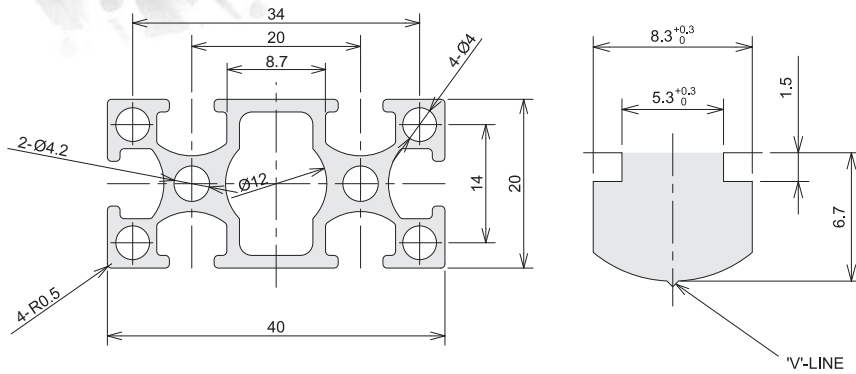

PROFILE



DF 3030 30 X 30

ORDER NUMBER **DY 5006**

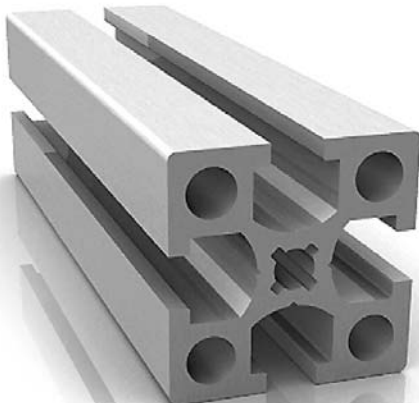

Technical Data (技術 Data)

Material (材質)	A6063-T5
Surface Processing (表面處理)	Anodized
Weight (重量)	1.073kg/m
Section Area (斷面積)	395.8259mm ²
Second Section Moment (斷面2次 Moment)	lx=3.6x10cm ⁴ ly=3.6x10cm ⁴
Specification (仕様)	4,000mm / 6,000mm
Color (色相)	Silver, Black
Application (用途)	Machine Structure Frame, Work Table, Machine Cover (기계구조물, 작업대, 기계커버)

CAD Drawing

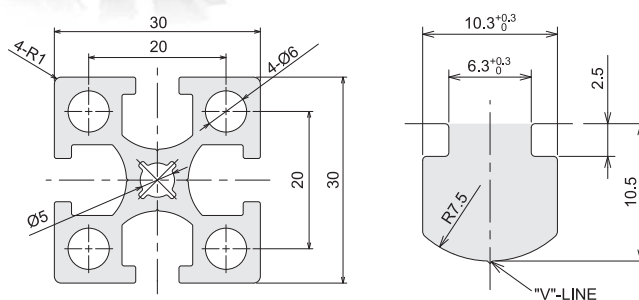

PROFILE



DF 3040 30 X 40

ORDER NUMBER **DY 5007**

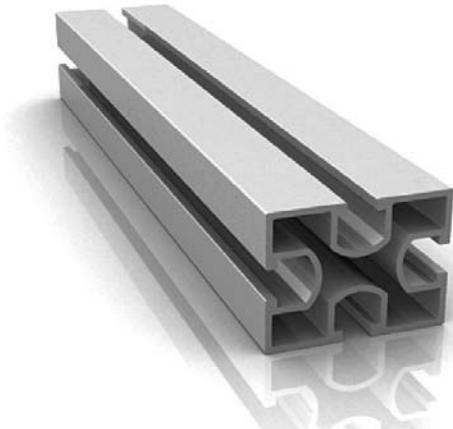

Technical Data (技術 Data)

Material (材質)	A6063-T5
Surface Processing (表面處理)	Anodized
Weight (重量)	0.882kg/m
Section Area (斷面積)	325.5917mm ²
Second Section Monent (斷面2次 Moment)	lx=3.2x10cm ⁴ ly=5.4x10cm ⁴
Specification (仕様)	4,000mm / 6,000mm
Color (色相)	Silver, Black
Application (用途)	Machine Structure Frame, Work Table, Machine Cover (기계구조물, 작업대, 기계커버)

CAD Drawing

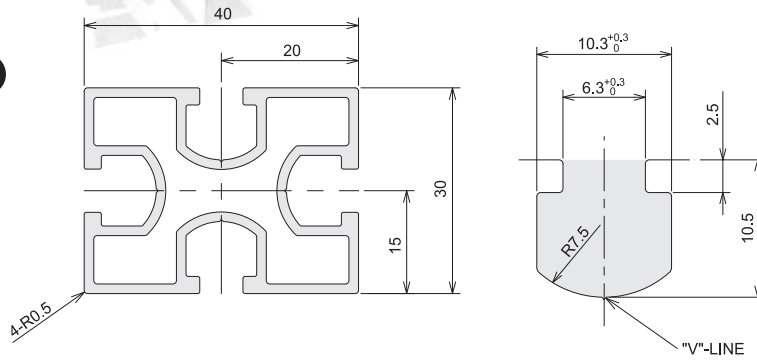

PROFILE



DF 3060 20 X 20

ORDER NUMBER **DY 5008**

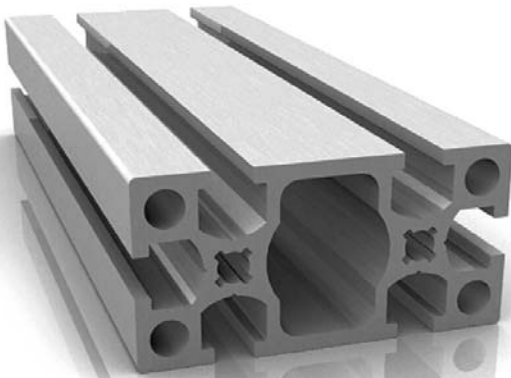

Technical Data (技術 Data)

Material (材質)	A6063-T5
Surface Processing (表面處理)	Anodized
Weight (重量)	1.797kg/m
Section Area (斷面積)	662.9518mm ²
Second Section Monent (斷面2次 Moment)	lx=6.5x10cm ⁴ ly=25.0x10cm ⁴
Specification (仕様)	4,000mm / 6,000mm
Color (色相)	Silver, Black
Application (用途)	Machine Structure Frame, Work Table, Machine Cover (기계구조물, 작업대, 기계커버)

CAD Drawing

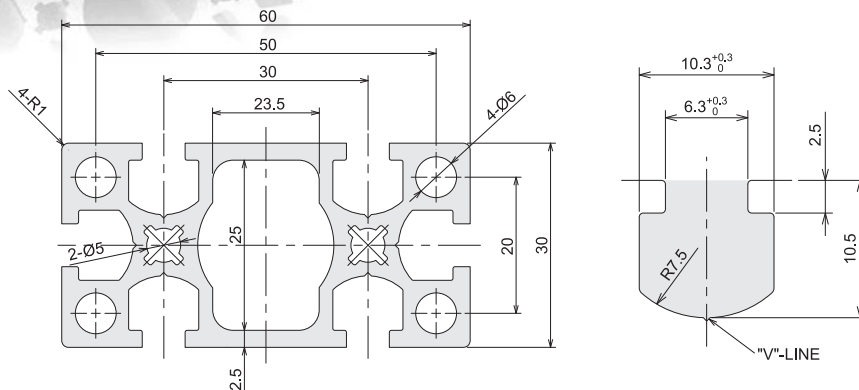

PROFILE



DF 3090 30 X 90

ORDER NUMBER **DY 5009**

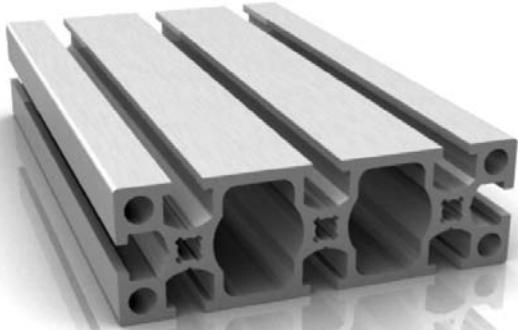

Technical Data (技術 Data)

Material (材質)	A6063-T5
Surface Processing (表面處理)	Anodized
Weight (重量)	2.543kg/m
Section Area (斷面積)	938.2560mm ²
Second Section Moment (斷面2次 Moment)	$I_x=9.5 \times 10 \text{cm}^4$ $I_y=76.2 \times 10 \text{cm}^4$
Specification (仕様)	4,000mm / 6,000mm
Color (色相)	Silver, Black
Application (用途)	Machine Structure Frame, Work Table, Machine Cover (기계구조물, 작업대, 기계커버)

CAD Drawing

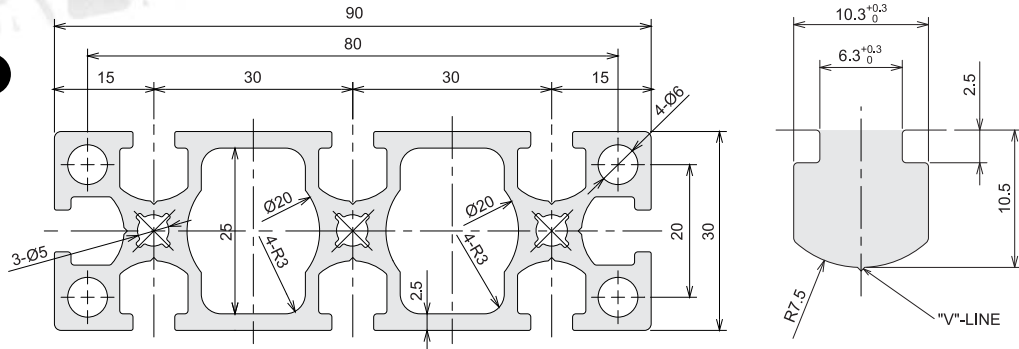

PROFILE



DF 30120 30 X 120

ORDER NUMBER **DY 5010**

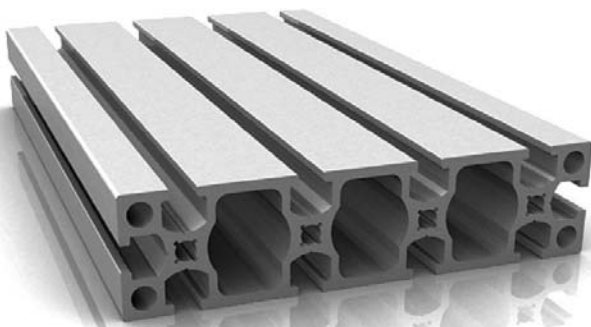

Technical Data (技術 Data)

Material (材質)	A6063-T5
Surface Processing (表面處理)	Anodized
Weight (重量)	3.279kg/m
Section Area (斷面積)	1,209.8395mm ²
Second Section Moment (斷面2次 Moment)	$I_x=12.4 \times 10 \text{cm}^4$ $I_y=169.7 \times 10 \text{cm}^4$
Specification (仕様)	4,000mm / 6,000mm
Color (色相)	Silver, Black
Application (用途)	Machine Structure Frame, Work Table, Machine Cover (기계구조물, 작업대, 기계커버)

CAD Drawing

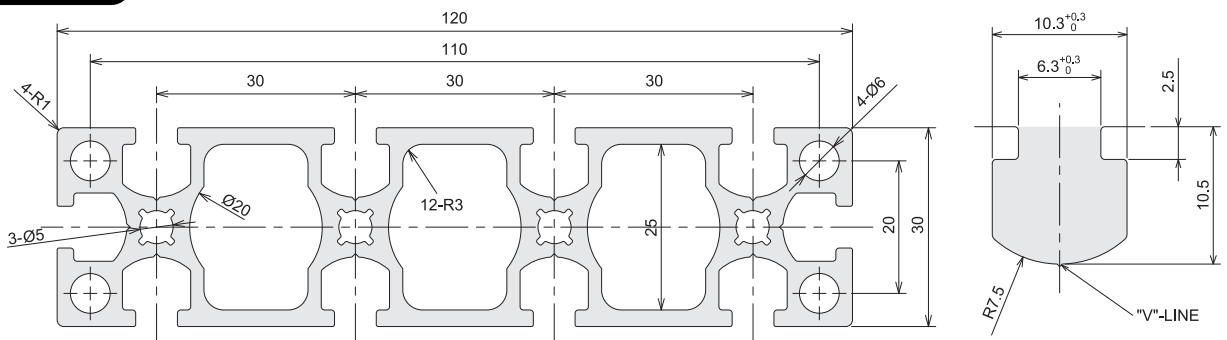

PROFILE



DF 3535 35 X 35

ORDER NUMBER **DY 5011**



Technical Data (技術 Data)

Material (材質)	A6063-T5
Surface Processing (表面處理)	Anodized
Weight (重量)	1.515kg/m
Section Area (斷面積)	559.0493mm ²
Second Section Monent (斷面2次 Moment)	lx=6.9x10cm ⁴ ly=6.9x10cm ⁴
Specification (仕様)	4,000mm / 6,000mm
Color (色相)	Silver, Black
Application (用途)	Machine Structure Frame, Work Table, Machine Cover (기계구조물, 작업대, 기계커버)

CAD Drawing

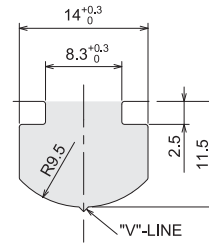
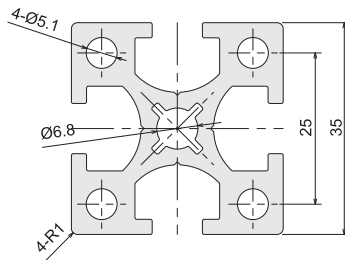

PROFILE



DF 3570 35 X 70

ORDER NUMBER **DY 5012**

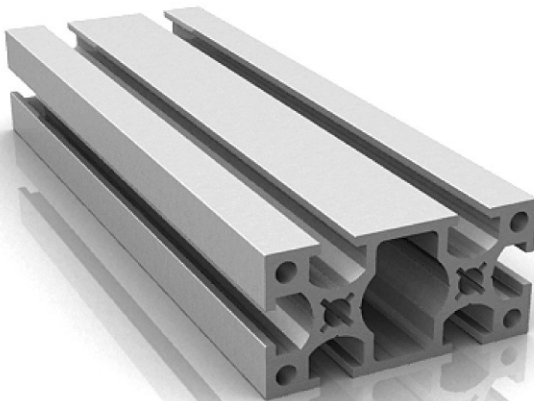

Technical Data (技術 Data)

Material (材質)	A6063-T5
Surface Processing (表面處理)	Anodized
Weight (重量)	2.493kg/m
Section Area (斷面積)	919.9457mm ²
Second Section Monent (斷面2次 Moment)	lx=11.8x10cm ⁴ ly=47.8x10cm ⁴
Specification (仕様)	4,000mm / 6,000mm
Color (色相)	Silver, Black
Application (用途)	Machine Structure Frame, Work Table, Machine Cover (기계구조물, 작업대, 기계커버)

CAD Drawing

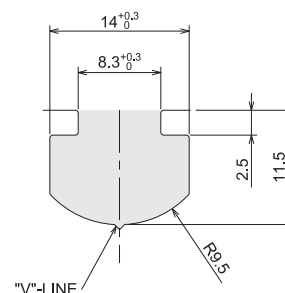
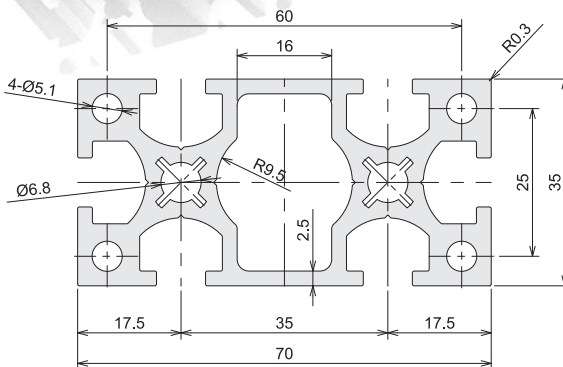

PROFILE



DF 4040 40 X 40

ORDER NUMBER **DY 5013**

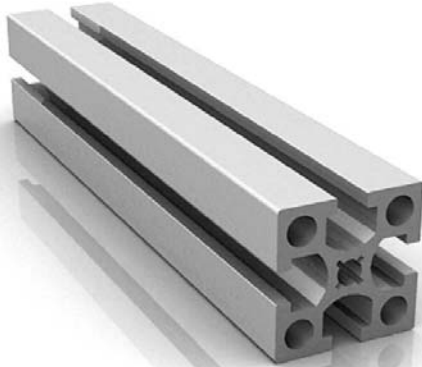

Technical Data (技術 Data)

Material (材質)	A6063-T5
Surface Processing (表面處理)	Anodized
Weight (重量)	1.909kg/m
Section Area (斷面積)	704.4335mm ²
Second Section Moment (斷面2次 Moment)	lx=11.4x10cm ⁴ ly=11.4x10cm ⁴
Specification (仕様)	4,000mm / 6,000mm
Color (色相)	Silver, Black
Application (用途)	Machine Structure Frame, Work Table, Machine Cover (기계구조물, 작업대, 기계커버)

CAD Drawing

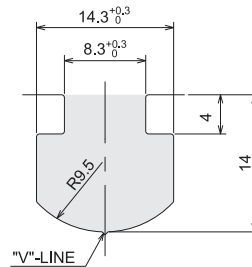
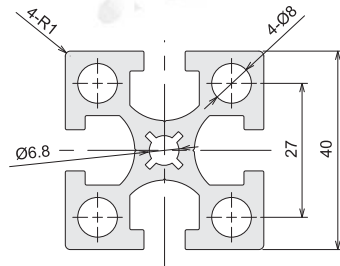

PROFILE



DF 4080 40 X 80

ORDER NUMBER **DY 5014**

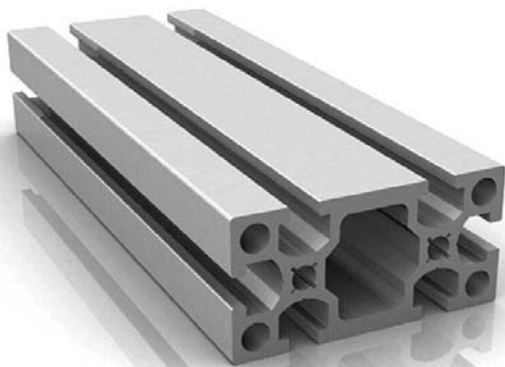

Technical Data (技術 Data)

Material (材質)	A6063-T5
Surface Processing (表面處理)	Anodized
Weight (重量)	3.391kg/m
Section Area (斷面積)	1,251.2626mm ²
Second Section Moment (斷面2次 Moment)	lx=22.5x10cm ⁴ ly=79.1x10cm ⁴
Specification (仕様)	4,000mm / 6,000mm
Color (色相)	Silver, Black
Application (用途)	Machine Structure Frame, Work Table, Machine Cover (기계구조물, 작업대, 기계커버)

CAD Drawing

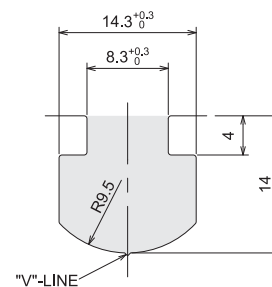
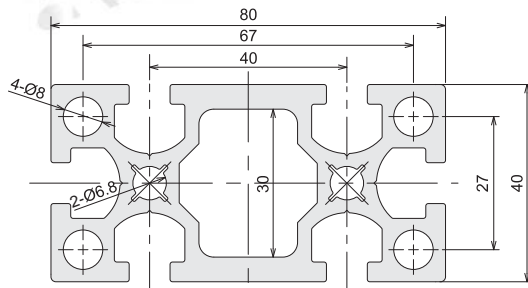

PROFILE



DF 40120 40 X 120

ORDER NUMBER **DY 5015**

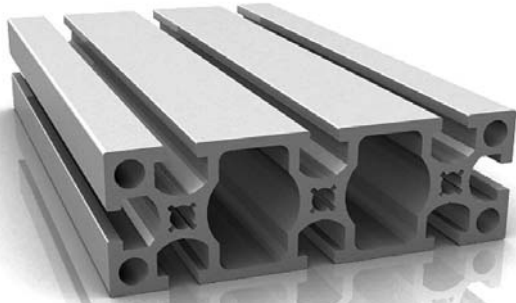

Technical Data (技術 Data)

Material (材質)	A6063-T5
Surface Processing (表面處理)	Anodized
Weight (重量)	4.553kg/m
Section Area (斷面積)	1,679.9169mm ²
Second Section Moment (斷面2次 Moment)	lx=29.8x10cm ⁴ ly=242.4x10cm ⁴
Specification (仕様)	4,000mm / 6,000mm
Color (色相)	Silver, Black
Application (用途)	Machine Structure Frame, Work Table, Machine Cover (기계구조물, 작업대, 기계커버)

CAD Drawing

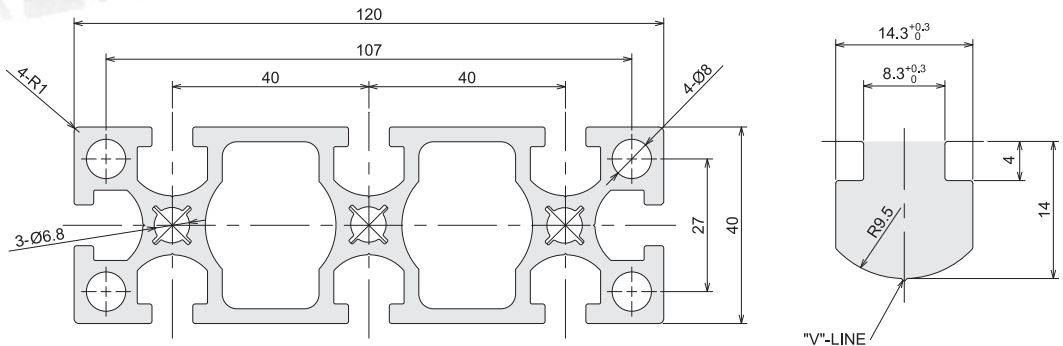

PROFILE



DF 40160 40 X 160

ORDER NUMBER **DY 5016**

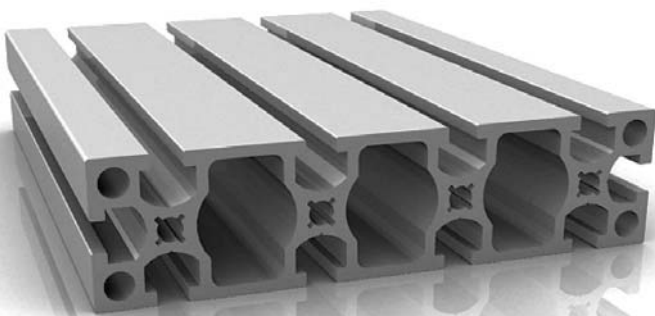

Technical Data (技術 Data)

Material (材質)	A6063-T5
Surface Processing (表面處理)	Anodized
Weight (重量)	5.837kg/m
Section Area (斷面積)	2,153.6719mm ²
Second Section Moment (斷面2次 Moment)	lx=38.9x10cm ⁴ ly=536.6x10cm ⁴
Specification (仕様)	4,000mm / 6,000mm
Color (色相)	Silver, Black
Application (用途)	Machine Structure Frame, Work Table, Machine Cover (기계구조물, 작업대, 기계커버)

CAD Drawing

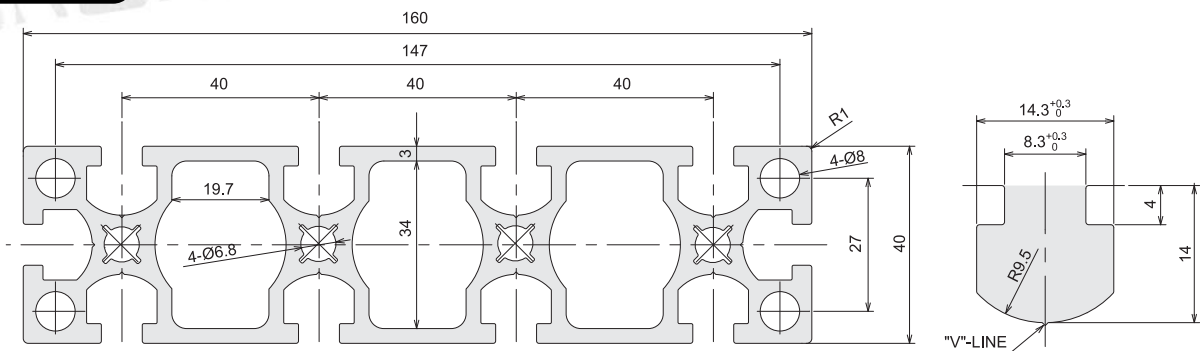

PROFILE



DF 4545 45 X 45

ORDER NUMBER **DY 5017**

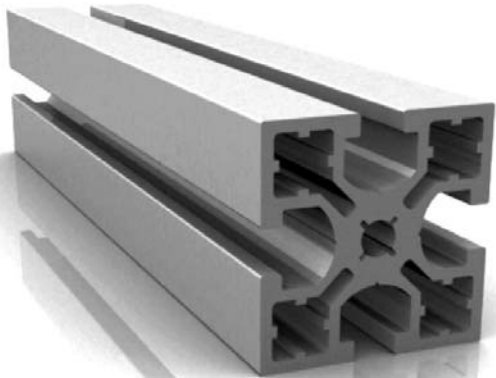

Technical Data (技術 Data)

Material (材質)	A6063-T5
Surface Processing (表面處理)	Anodized
Weight (重量)	2.192kg/m
Section Area (斷面積)	808.6545mm ²
Second Section Moment (斷面2次 Moment)	I _x =15.1x10cm ⁴ I _y =15.1x10cm ⁴
Specification (仕様)	4,000mm / 6,000mm
Color (色相)	Silver, Black
Application (用途)	Machine Structure Frame, Work Table, Machine Cover (기계구조물, 작업대, 기계커버)

CAD Drawing

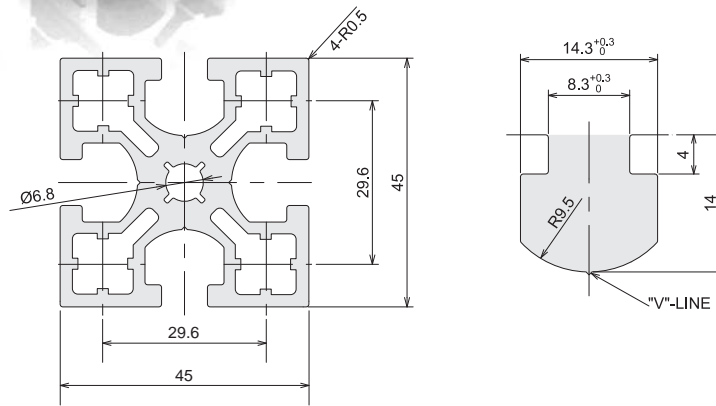

PROFILE



DF 4560 45 X 60

ORDER NUMBER **DY 5018**

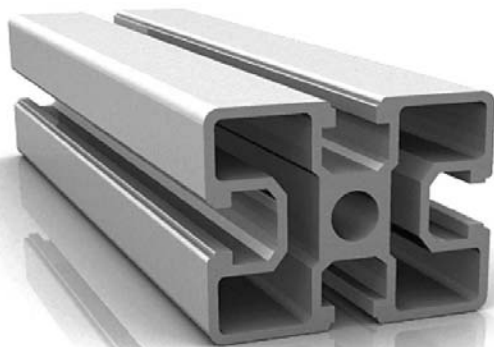

Technical Data (技術 Data)

Material (材質)	A6063-T5
Surface Processing (表面處理)	Anodized
Weight (重量)	2.257kg/m
Section Area (斷面積)	832.9669mm ²
Second Section Moment (斷面2次 Moment)	I _x =16.2x10cm ⁴ I _y =27.2x10cm ⁴
Specification (仕様)	4,000mm / 6,000mm
Color (色相)	Silver, Black
Application (用途)	Machine Structure Frame, Work Table, Machine Cover (기계구조물, 작업대, 기계커버)

CAD Drawing

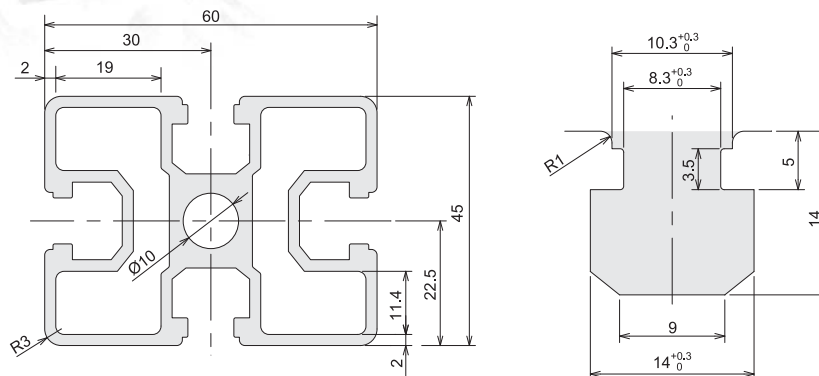

PROFILE



DF 4590 45 X 90

ORDER NUMBER **DY 5019**



Technical Data (技術 Data)

Material (材質)	A6063-T5
Surface Processing (表面處理)	Anodized
Weight (重量)	3.758kg/m
Section Area (斷面積)	1,386.5591mm ²
Second Section Monent (斷面2次 Moment)	lx=28.6x10cm ⁴ ly=111.9x10cm ⁴
Specification (仕様)	4,000mm / 6,000mm
Color (色相)	Silver, Black
Application (用途)	Machine Structure Frame, Work Table, Machine Cover (기계구조물, 작업대, 기계커버)

CAD Drawing

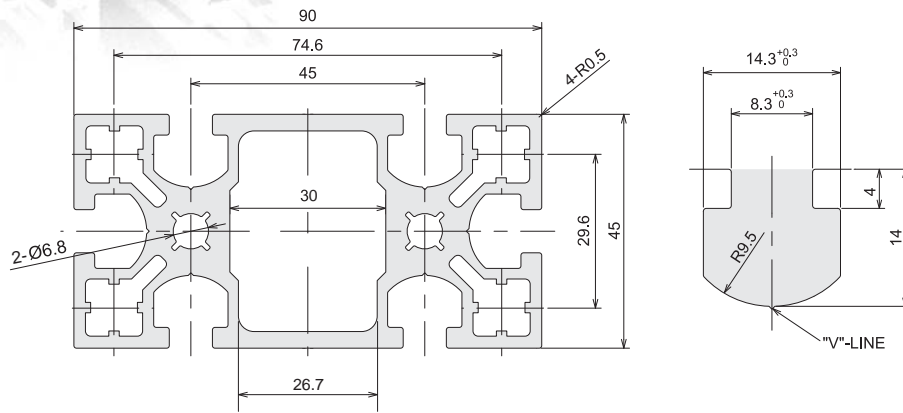

PROFILE



DF 5050 50 X 50

ORDER NUMBER **DY 5020**

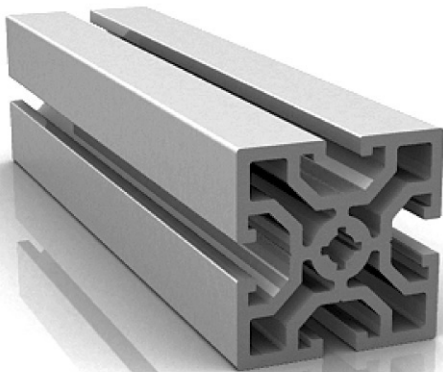

Technical Data (技術 Data)

Material (材質)	A6063-T5
Surface Processing (表面處理)	Anodized
Weight (重量)	3.009kg/m
Section Area (斷面積)	1,110.1478mm ²
Second Section Monent (斷面2次 Moment)	lx=25.9x10cm ⁴ ly=25.9x10cm ⁴
Specification (仕様)	4,000mm / 6,000mm
Color (色相)	Silver, Black
Application (用途)	Machine Structure Frame, Work Table, Machine Cover (기계구조물, 작업대, 기계커버)

CAD Drawing

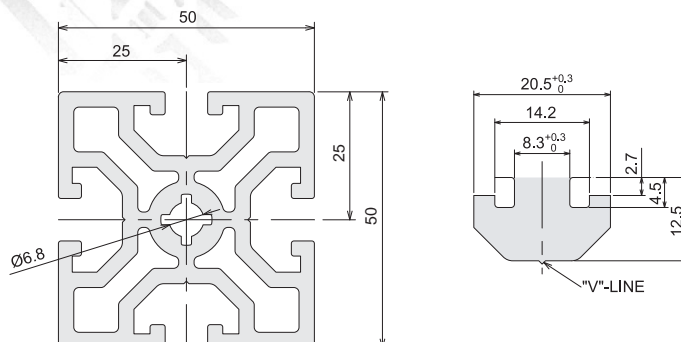

PROFILE



DF 6060 60 X 60

ORDER NUMBER **DY 5021**



Technical Data (技術 Data)

Material (材質)	A6063-T5
Surface Processing (表面處理)	Anodized
Weight (重量)	2.718kg/m
Section Area (斷面積)	1,002.9632mm ²
Second Section Moment (斷面2次 Moment)	lx=42.3x10cm ⁴ ly=42.3x10cm ⁴
Specification (仕様)	4,000mm / 6,000mm
Color (色相)	Silver, Black
Application (用途)	Machine Structure Frame, Work Table, Machine Cover (기계구조물, 작업대, 기계커버)

CAD Drawing

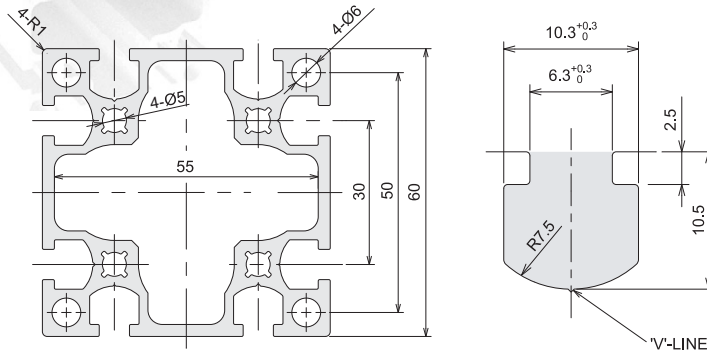

PROFILE



DF 6090 60 X 90

ORDER NUMBER **DY 5022**



Technical Data (技術 Data)

Material (材質)	A6063-T5
Surface Processing (表面處理)	Anodized
Weight (重量)	3.385kg/m
Section Area (斷面積)	1,249.2065mm ²
Second Section Moment (斷面2次 Moment)	lx=58.1x10cm ⁴ ly=123.2x10cm ⁴
Specification (仕様)	4,000mm / 6,000mm
Color (色相)	Silver, Black
Application (用途)	Machine Structure Frame, Work Table, Machine Cover (기계구조물, 작업대, 기계커버)

CAD Drawing

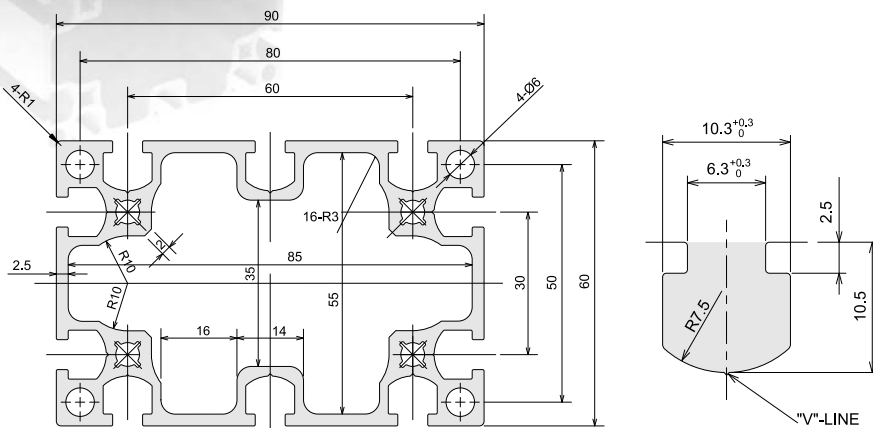

PROFILE



DF 60120 60 X 120

ORDER NUMBER **DY 5147**



Technical Data (技術 Data)

Material (材質)	A6063-T5
Surface Processing (表面處理)	Anodized
Weight (重量)	4.673kg/m
Section Area (斷面積)	1,724.3132mm ²
Second Section Moment (斷面2次 Moment)	lx=75.53x10cm ⁴ ly=264.24x10cm ⁴
Specification (仕様)	4,000mm / 6,000mm
Color (色相)	Silver, Black
Application (用途)	Machine Structure Frame, Work Table, Machine Cover (기계구조물, 작업대, 기계커버)

CAD Drawing

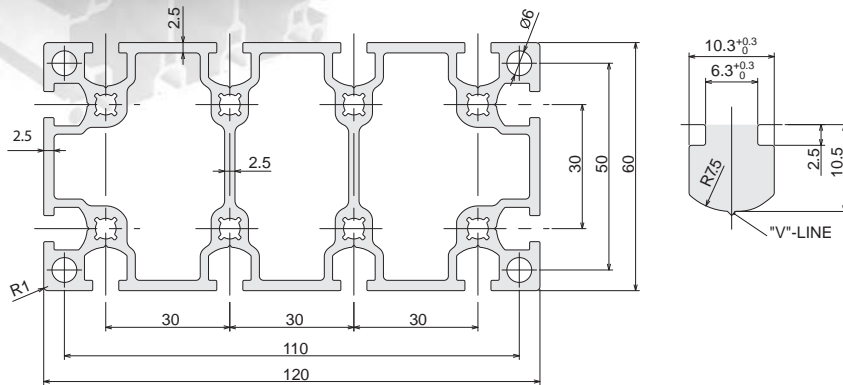

PROFILE



DF 8080 80 X 80

ORDER NUMBER **DY 5024**

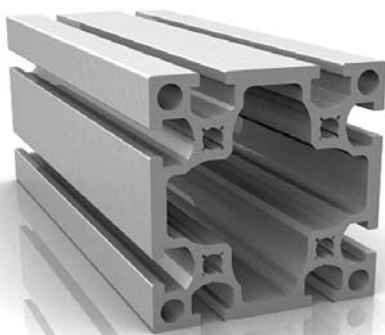

Technical Data (技術 Data)

Material (材質)	A6063-T5
Surface Processing (表面處理)	Anodized
Weight (重量)	5.238kg/m
Section Area (斷面積)	1,932.7603mm ²
Second Section Moment (斷面2次 Moment)	lx=144.1x10cm ⁴ ly=144.1x10cm ⁴
Specification (仕様)	4,000mm / 6,000mm
Color (色相)	Silver, Black
Application (用途)	Machine Structure Frame, Work Table, Machine Cover (기계구조물, 작업대, 기계커버)

CAD Drawing

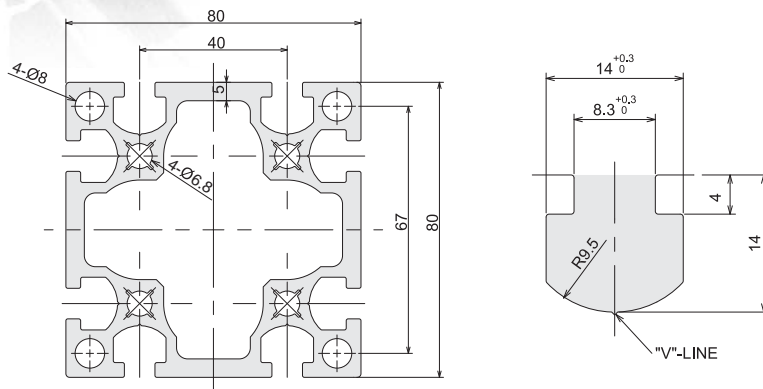

PROFILE



DF 80120 80 X 120

ORDER NUMBER **DY 5025**



Technical Data (技術 Data)

Material (材質)	A6063-T5
Surface Processing (表面處理)	Anodized
Weight (重量)	6.863kg/m
Section Area (斷面積)	2,532.4818mm ²
Second Section Monent (斷面2次 Moment)	Ix=192.2x10cm ⁴ Iy=393.6x10cm ⁴
Specification (仕様)	4,000mm / 6,000mm
Color (色相)	Silver, Black
Application (用途)	Machine Structure Frame, Work Table, Machine Cover (기계구조물, 작업대, 기계커버)

CAD Drawing

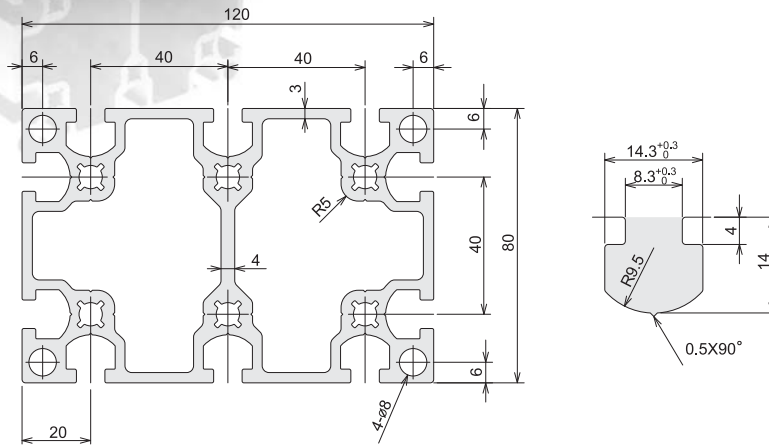

PROFILE



DF 80160 80 X 160

ORDER NUMBER **DY 5150**



Technical Data (技術 Data)

Material (材質)	A6063-T5
Surface Processing (表面處理)	Anodized
Weight (重量)	9.227kg/m
Section Area (斷面積)	3,404.7559mm ²
Second Section Monent (斷面2次 Moment)	Ix=253.2x10cm ⁴ Iy=862.1x10cm ⁴
Specification (仕様)	4,000mm / 6,000mm
Color (色相)	Silver, Black
Application (用途)	Machine Structure Frame, Work Table, Machine Cover (기계구조물, 작업대, 기계커버)

CAD Drawing

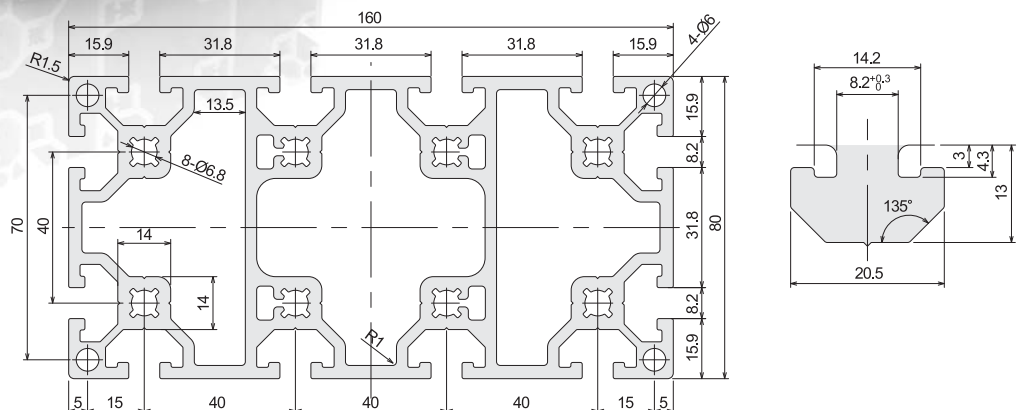

PROFILE



DF 9090 90 X 90

ORDER NUMBER **DY 5027**



Technical Data (技術 Data)

Material (材質)	A6063-T5
Surface Processing (表面處理)	Anodized
Weight (重量)	5.862kg/m
Section Area (斷面積)	2,162.9291mm ²
Second Section Monent (斷面2次 Moment)	lx=198.0x10cm ⁴ ly=198.0x10cm ⁴
Specification (仕様)	4,000mm / 6,000mm
Color (色相)	Silver, Black
Application (用途)	Machine Structure Frame, Work Table, Machine Cover (기계구조물, 작업대, 기계커버)

CAD Drawing

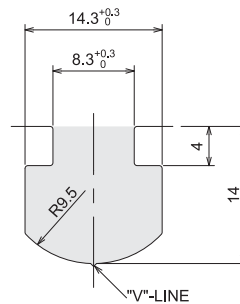
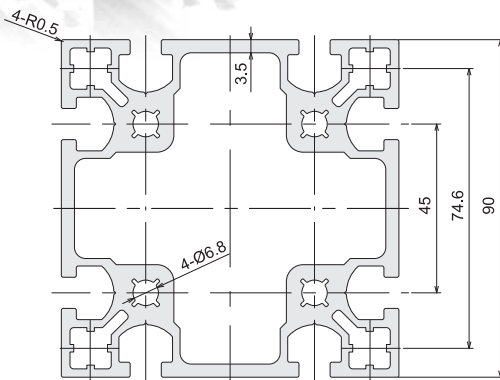

PROFILE



DF 6630 66 X 30

ORDER NUMBER **DY 5023**



Technical Data (技術 Data)

Material (材質)	A6063-T5
Surface Processing (表面處理)	Anodized
Weight (重量)	2.179kg/m
Section Area (斷面積)	804.1209mm ²
Second Section Monent (斷面2次 Moment)	lx=19.8x10cm ⁴ ly=40.0x10cm ⁴
Specification (仕様)	4,000mm / 6,000mm
Color (色相)	Silver, Black
Application (用途)	Coner Frame, Machine Structure Frame, Work Table, Machine Cover (코너용 프로파일, 기계구조물, 작업대, 기계커버)

CAD Drawing

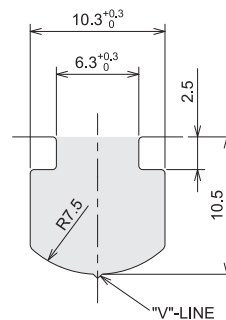
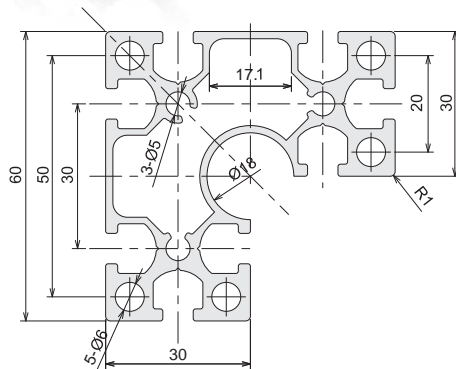

PROFILE



DF 8840 88 X 40

ORDER NUMBER **DY 5026**



Technical Data (技術 Data)

Material (材質)	A6063-T5
Surface Processing (表面處理)	Anodized
Weight (重量)	4.01kg/m
Section Area (斷面積)	1,479.7387mm ²
Second Section Moment (斷面2次 Moment)	lx=63.8x10cm ⁴ ly=128.4x10cm ⁴
Specification (仕様)	4,000mm / 6,000mm
Color (色相)	Silver, Black
Application (用途)	Coner Frame, Machine Structure Frame, Work Table, Machine Cover (코너용 프레임, 기계구조물, 작업대, 기계커버)

CAD Drawing

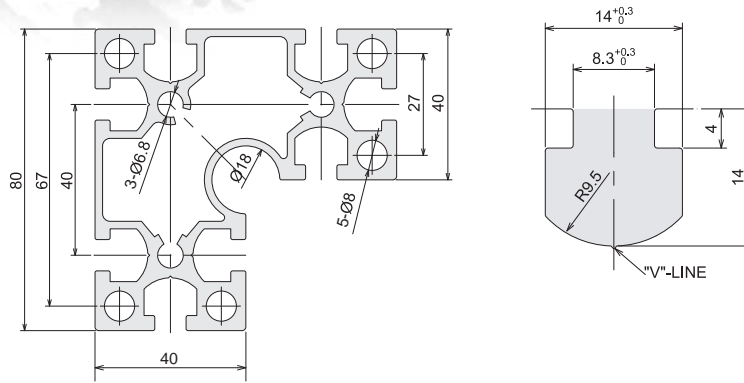

PROFILE



DFR 6060 60 X 60

ORDER NUMBER **DY 5181**



Technical Data (技術 Data)

Material (材質)	A6063-T5
Surface Processing (表面處理)	Anodized
Weight (重量)	2.094kg/m
Section Area (斷面積)	772.5573mm ²
Second Section Moment (斷面2次 Moment)	lx=13.8x10cm ⁴ ly=40.2x10cm ⁴
Specification (仕様)	4,000mm / 6,000mm
Color (色相)	Silver, Black
Application (用途)	Machine Structure Frame, Work Table, Machine Cover (기계구조물, 작업대, 기계커버)

CAD Drawing

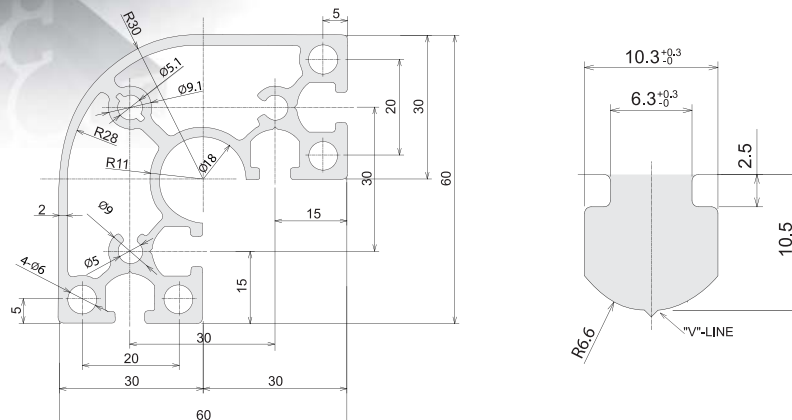

PROFILE



DNF 3030 30 X 30

ORDER NUMBER **DY 5155**

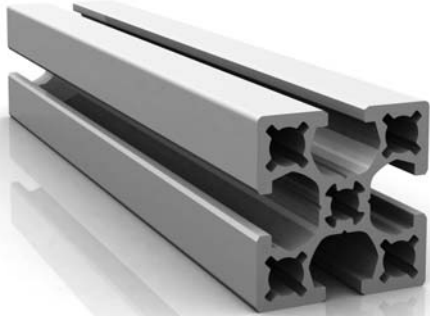

Technical Data (技術 Data)

Material (材質)	A6063-T5
Surface Processing (表面處理)	Anodized
Weight (重量)	0.85kg/m
Section Area (斷面積)	313.5818mm ²
Second Section Monent (斷面2次 Moment)	lx=3.02x10cm ⁴ ly=3.02x10cm ⁴
Specification (仕様)	4,000mm / 6,000mm
Color (色相)	Silver, Black
Application (用途)	Machine Structure Frame, Work Table, Machine Cover (기계구조물, 작업대, 기계커버)

CAD Drawing

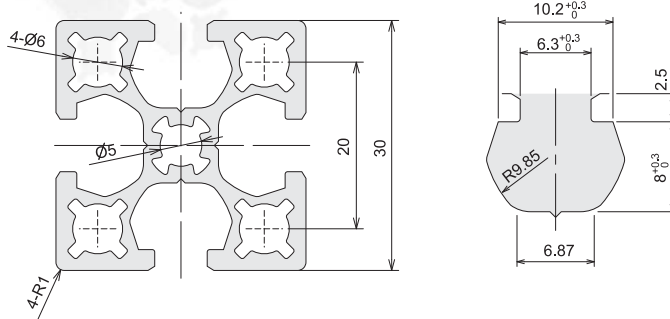

PROFILE



DNF 3060 30 X 60

ORDER NUMBER **DY 5156**



Technical Data (技術 Data)

Material (材質)	A6063-T5
Surface Processing (表面處理)	Anodized
Weight (重量)	1.451kg/m
Section Area (斷面積)	535.3037mm ²
Second Section Monent (斷面2次 Moment)	lx=5.5x10cm ⁴ ly=20.2x10cm ⁴
Specification (仕様)	4,000mm / 6,000mm
Color (色相)	Silver, Black
Application (用途)	Machine Structure Frame, Work Table, Machine Cover (기계구조물, 작업대, 기계커버)

CAD Drawing

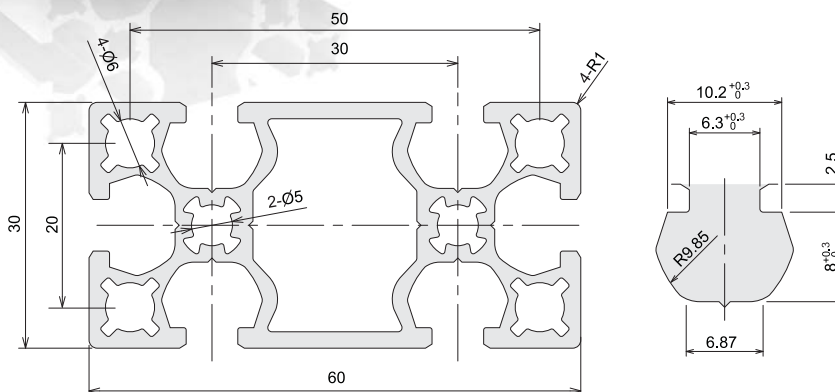

PROFILE



DNF 3090 30 X 30

ORDER NUMBER **DY 5177**



Technical Data (技術 Data)

Material (材質)	A6063-T5
Surface Processing (表面處理)	Anodized
Weight (重量)	2.118kg/m
Section Area (斷面積)	781.4594mm ²
Second Section Moment (斷面2次 Moment)	lx=8.15x10cm ⁴ ly=62.17x10cm ⁴
Specification (仕様)	4,000mm / 6,000mm
Color (色相)	Silver, Black
Application (用途)	Machine Structure Frame, Work Table, Machine Cover, (기계구조물, 작업대, 기계커버)

CAD Drawing

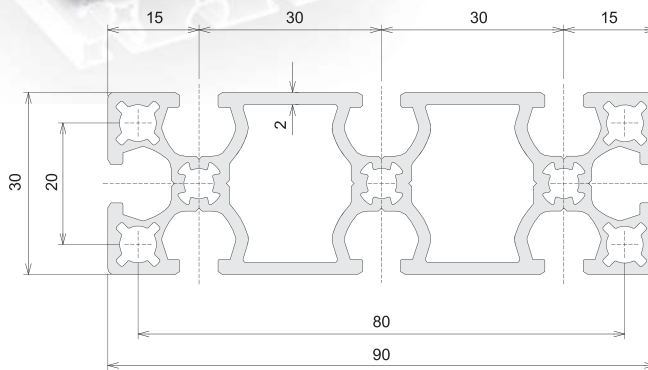

PROFILE



DNF 30120 30 X 120

ORDER NUMBER **DY 5178**



Technical Data (技術 Data)

Material (材質)	A6063-T5
Surface Processing (表面處理)	Anodized
Weight (重量)	2.847kg/m
Section Area (斷面積)	1,050.6480mm ²
Second Section Moment (斷面2次 Moment)	lx=10.7x10cm ⁴ ly=147.0x10cm ⁴
Specification (仕様)	4,000mm / 6,000mm
Color (色相)	Silver, Black
Application (用途)	Machine Structure Frame, Work Table, Machine Cover, (기계구조물, 작업대, 기계커버)

CAD Drawing

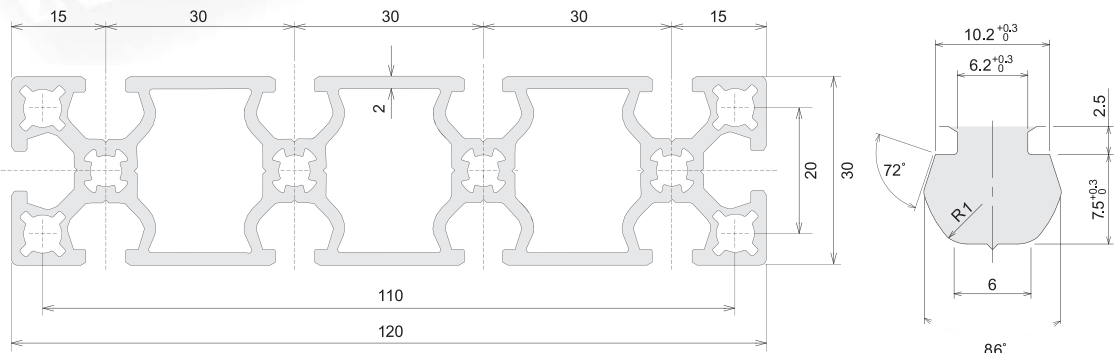

PROFILE



DNF 4040 40 X 40

ORDER NUMBER **DY 5028**



Technical Data (技術 Data)

Material (材質)	A6063-T5
Surface Processing (表面處理)	Anodized
Weight (重量)	1.680kg/m
Section Area (斷面積)	620.0254mm ²
Second Section Monent (斷面2次 Moment)	lx=10.0x10cm ⁴ ly=10.0x10cm ⁴
Specification (仕様)	4,000mm / 6,000mm
Color (色相)	Silver, Black
Application (用途)	Machine Structure Frame, Work Table, Machine Cover (기계구조물, 작업대, 기계커버)

CAD Drawing

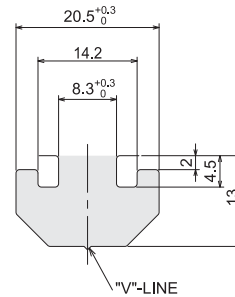
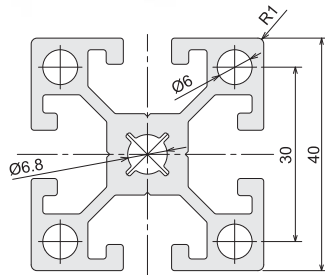

PROFILE



DNF 4040B 40 X 40

ORDER NUMBER **DY 5230**

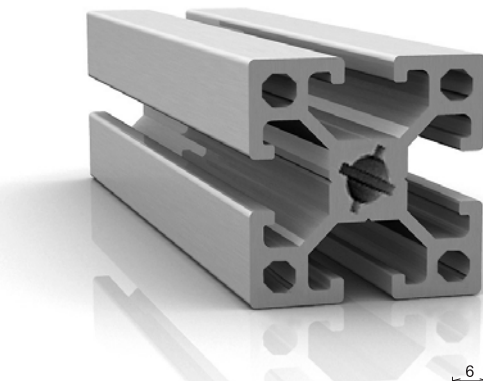

Technical Data (技術 Data)

Material (材質)	A6063-T5
Surface Processing (表面處理)	Anodized
Weight (重量)	1.58kg/m
Section Area (斷面積)	583.7836mm ²
Second Section Monent (斷面2次 Moment)	lx=9.55x10cm ⁴ ly=9.55x10cm ⁴
Specification (仕様)	4,000mm / 6,000mm
Color (色相)	Silver, Black
Application (用途)	Machine Structure Frame, Work Table, Machine Cover (기계구조물, 작업대, 기계커버)

CAD Drawing

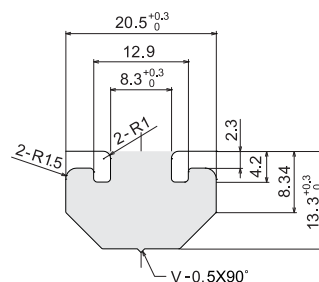
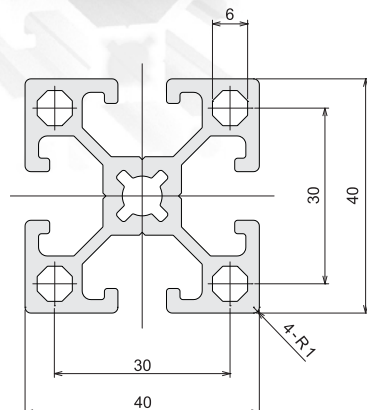

PROFILE



DNF 4080 40 X 80

ORDER NUMBER **DY 5029**



Technical Data (技術 Data)

Material (材質)	A6063-T5
Surface Processing (表面處理)	Anodized
Weight (重量)	2.729kg/m
Section Area (斷面積)	1,007.1055mm ²
Second Section Moment (斷面2次 Moment)	lx=17.2x10cm ⁴ ly=68.4x10cm ⁴
Specification (仕様)	4,000mm / 6,000mm
Color (色相)	Silver, Black
Application (用途)	Machine Structure Frame, Work Table, Machine Cover (기계구조물, 작업대, 기계커버)

CAD Drawing

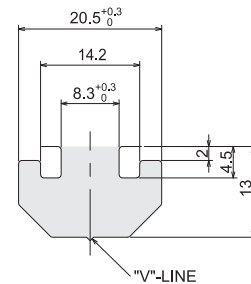
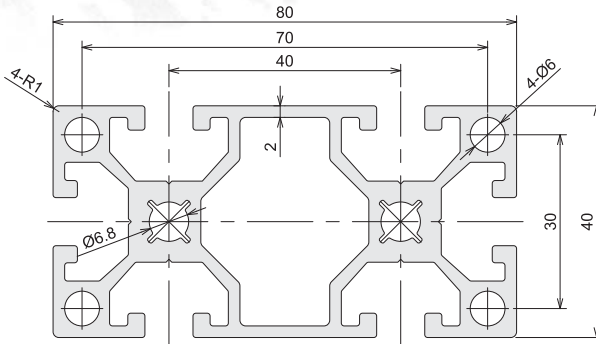

PROFILE



DNF 4080B 40 X 80

ORDER NUMBER **DY 5231**

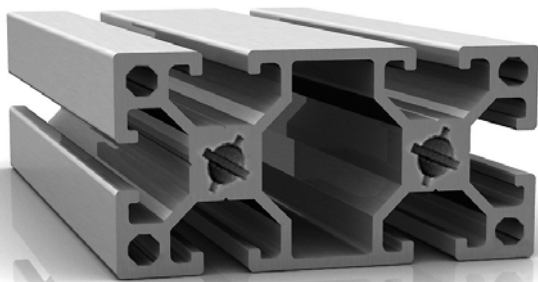

Technical Data (技術 Data)

Material (材質)	A6063-T5
Surface Processing (表面處理)	Anodized
Weight (重量)	2.631kg/m
Section Area (斷面積)	970.7871mm ²
Second Section Moment (斷面2次 Moment)	lx=16.78x10cm ⁴ ly=65.58x10cm ⁴
Specification (仕様)	4,000mm / 6,000mm
Color (色相)	Silver, Black
Application (用途)	Machine Structure Frame, Work Table, Machine Cover, Door&Windows Frame, SensorBracket (기계구조물, 작업대, 기계커버)

CAD Drawing

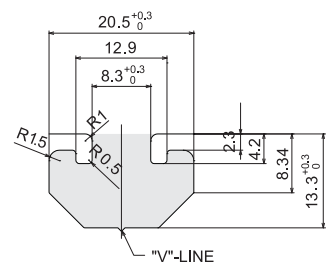
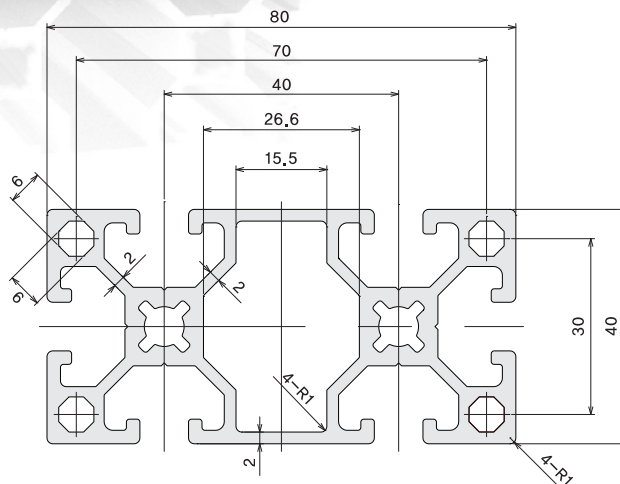

PROFILE



DNF 6060 60 X 60

ORDER NUMBER **DY 5163**



CAD Drawing

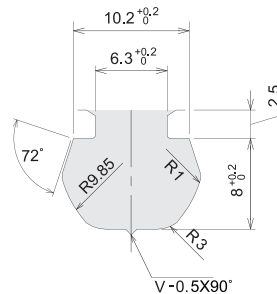
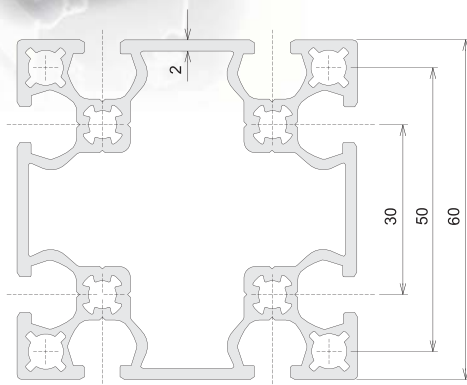

Technical Data (技術 Data)

Material (材質)	A6063-T5
Surface Processing (表面處理)	Anodized
Weight (重量)	2.226kg/m
Section Area (斷面積)	821.3375mm ²
Second Section Monent (斷面2次 Moment)	lx=34.8x10cm ⁴ ly=34.8x10cm ⁴
Specification (仕様)	4,000mm / 6,000mm
Color (色相)	Silver, Black
Application (用途)	Machine Structure Frame, Work Table, Machine Cover, (기계구조물, 작업대, 기계커버)

PROFILE



DNF 6090 60 X 90

ORDER NUMBER **DY 5164**



CAD Drawing

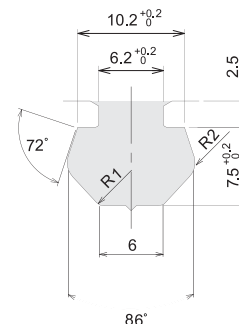
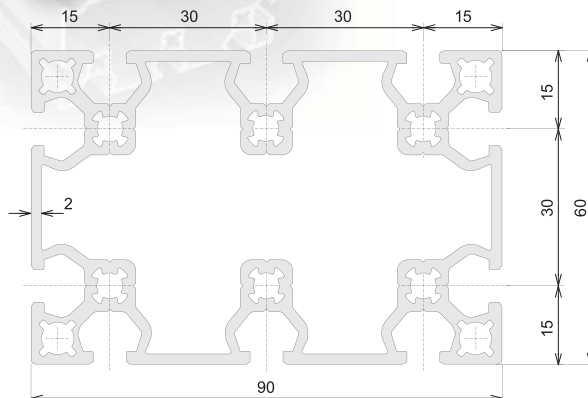

Technical Data (技術 Data)

Material (材質)	A6063-T5
Surface Processing (表面處理)	Anodized
Weight (重量)	3.195kg/m
Section Area (斷面積)	1,179.0593mm ²
Second Section Monent (斷面2次 Moment)	lx=52.13x10cm ⁴ ly=107.54x10cm ⁴
Specification (仕様)	4,000mm / 6,000mm
Color (色相)	Silver, Black
Application (用途)	Machine Structure Frame, Work Table, Machine Cover, (기계구조물, 작업대, 기계커버)

PROFILE



DNF 8080 80 X 80

ORDER NUMBER **DY 5030**

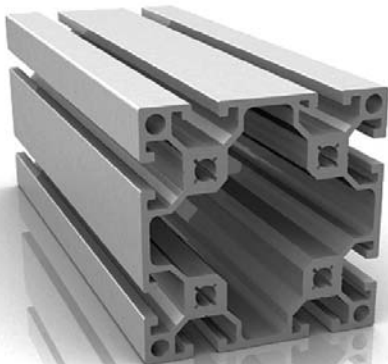

Technical Data (技術 Data)

Material (材質)	A6063-T5
Surface Processing (表面處理)	Anodized
Weight (重量)	4.37kg/m
Section Area (斷面積)	1,612.4204mm ²
Second Section Moment (斷面2次 Moment)	lx=118.3x10cm ⁴ ly=118.3x10cm ⁴
Specification (仕様)	4,000mm / 6,000mm
Color (色相)	Silver, Black
Application (用途)	Machine Structure Frame, Work Table, Machine Cover (기계구조물, 작업대, 기계커버)

CAD Drawing

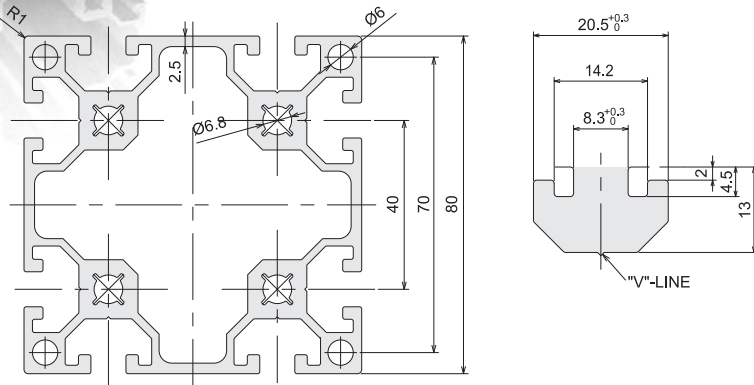

PROFILE



DNF 8080B 80 X 80

ORDER NUMBER **DY 5232**

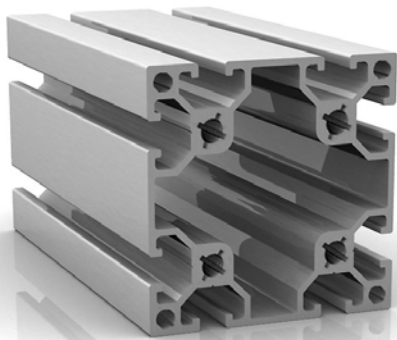

Technical Data (技術 Data)

Material (材質)	A6063-T5
Surface Processing (表面處理)	Anodized
Weight (重量)	4.009kg/m
Section Area (斷面積)	1,479.2950mm ²
Second Section Moment (斷面2次 Moment)	lx=110.57x10cm ⁴ ly=110.57x10cm ⁴
Specification (仕様)	4,000mm / 6,000mm
Color (色相)	Silver, Black
Application (用途)	Machine Structure Frame, Work Table, Machine Cover, (기계구조물, 작업대, 기계커버)

CAD Drawing

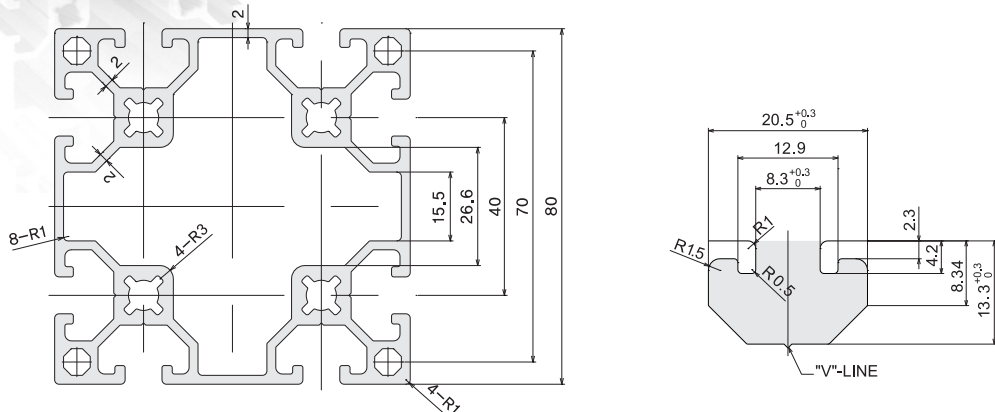

PROFILE



DHF 4040 40 X 40

ORDER NUMBER **DY 5031**



CAD Drawing

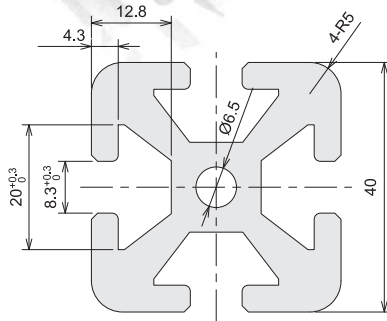

Technical Data (技術 Data)

Material (材質)	A6063-T5
Surface Processing (表面處理)	Anodized
Weight (重量)	2.364kg/m
Section Area (斷面積)	872.3799mm ²
Second Section Monent (斷面2次 Moment)	lx=13.7x10cm ⁴ ly=13.7x10cm ⁴
Specification (仕様)	4,000mm / 6,000mm
Color (色相)	Silver, Black
Application (用途)	Machine Structure Frame, Work Table, Machine Cover (기계구조물, 작업대, 기계커버)

PROFILE



DHF 4080 40 X 80

ORDER NUMBER **DY 5032**

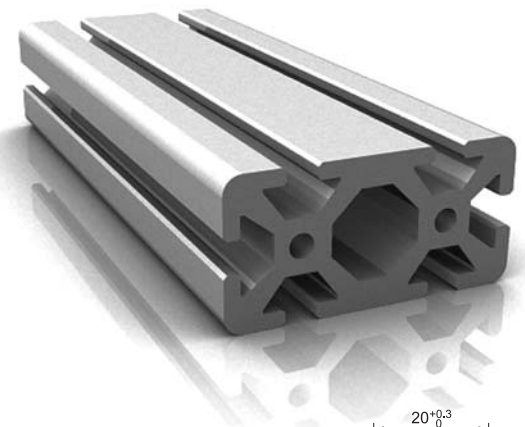

CAD Drawing

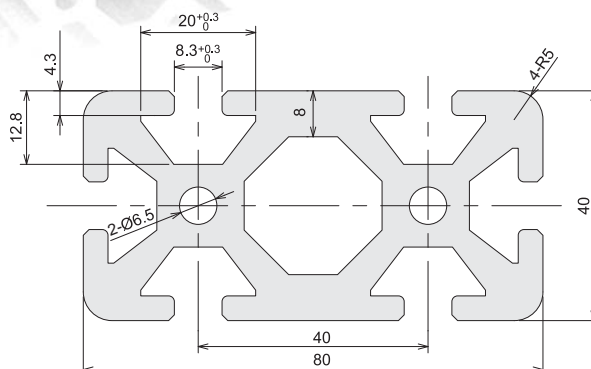

Technical Data (技術 Data)

Material (材質)	A6063-T5
Surface Processing (表面處理)	Anodized
Weight (重量)	4.03kg/m
Section Area (斷面積)	1,487.1534mm ²
Second Section Monent (斷面2次 Moment)	lx=27.1x10cm ⁴ ly=97.5x10cm ⁴
Specification (仕様)	4,000mm / 6,000mm
Color (色相)	Silver, Black
Application (用途)	Machine Structure Frame, Work Table, Machine Cover (기계구조물, 작업대, 기계커버)

PROFILE



DCF 2020-1 20 X 20

ORDER NUMBER **DY 5183**

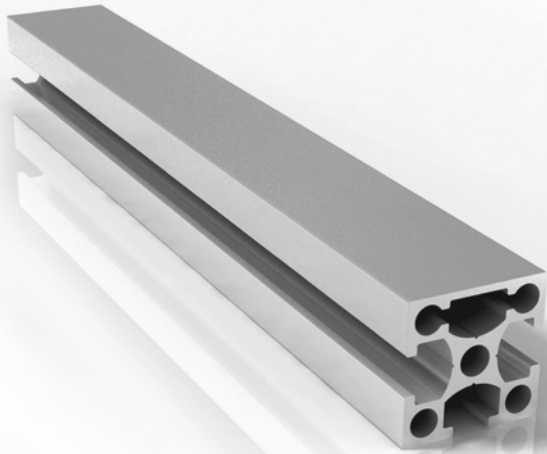

Technical Data (技術 Data)

Material (材質)	A6063-T5
Surface Processing (表面處理)	Anodized
Weight (重量)	0.396kg/m
Section Area (斷面積)	146.0129mm ²
Second Section Moment (斷面2次 Moment)	lx=0.61x10cm ⁴ ly=0.58x10cm ⁴
Specification (仕様)	4,000mm / 6,000mm
Color (色相)	Silver, Black
Application (用途)	Machine Structure Frame, Work Table, Machine Cover (기계구조물, 작업대, 기계커버)

CAD Drawing

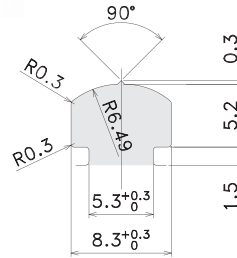
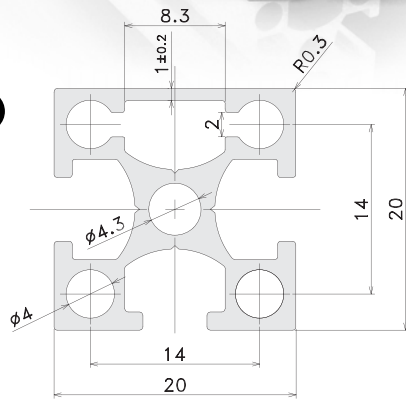

PROFILE



DCF 2040-1 20 X 40

ORDER NUMBER **DY 5184**



Technical Data (技術 Data)

Material (材質)	A6063-T5
Surface Processing (表面處理)	Anodized
Weight (重量)	0.752kg/m
Section Area (斷面積)	277.6304mm ²
Second Section Moment (斷面2次 Moment)	lx=1.2x10cm ⁴ ly=4.1x10cm ⁴
Specification (仕様)	4,000mm / 6,000mm
Color (色相)	Silver, Black
Application (用途)	Machine Structure Frame, Work Table, Machine Cover (기계구조물, 작업대, 기계커버)

CAD Drawing

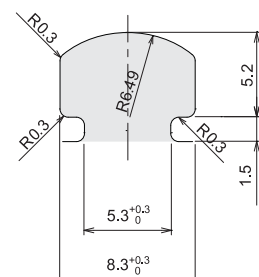
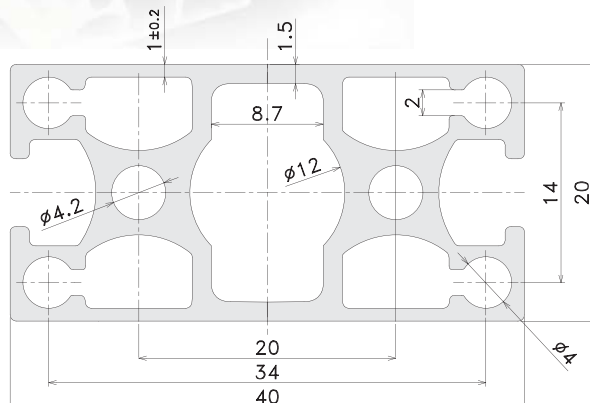

PROFILE



DCF 3030-1 30 X 30

ORDER NUMBER **DY 5035**



CAD Drawing

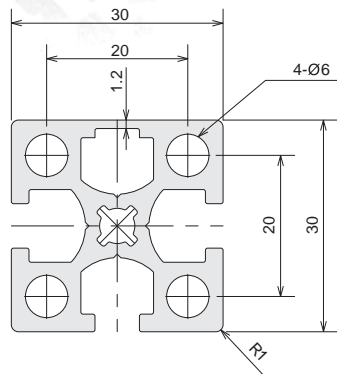

Technical Data (技術 Data)

Material (材質)	A6063-T5
Surface Processing (表面處理)	Anodized
Weight (重量)	1.086kg/m
Section Area (斷面積)	400.6816mm ²
Second Section Monent (斷面2次 Moment)	lx=3.83x10cm ⁴ ly=3.59x10cm ⁴
Specification (仕様)	4,000mm / 6,000mm
Color (色相)	Silver, Black
Application (用途)	Prevention of Foreign Material Machine Structure Frame, Work Table, Machine Cover (제작 후 이물질 유입방지 타입, 기계구조물, 작업대 기계커버)

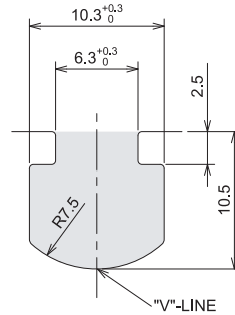

PROFILE



DCF 3030-2 30 X 30

ORDER NUMBER **DY 5130**



CAD Drawing

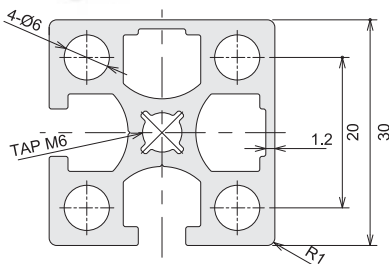

Technical Data (技術 Data)

Material (材質)	A6063-T5
Surface Processing (表面處理)	Anodized
Weight (重量)	1.104kg/m
Section Area (斷面積)	407.2088mm ²
Second Section Monent (斷面2次 Moment)	lx=3.7x10cm ⁴ ly=3.7x10cm ⁴
Specification (仕様)	4,000mm / 6,000mm
Color (色相)	Silver, Black
Application (用途)	Prevention of Foreign Material Machine Structure Frame, Work Table, Machine Cover (제작 후 이물질 유입방지 타입, 기계구조물, 작업대 기계커버)

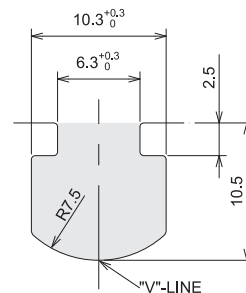

PROFILE



DCF 3030-3 30 X 30

ORDER NUMBER **DY 5144**



Technical Data (技術 Data)

Material (材質)	A6063-T5
Surface Processing (表面處理)	Anodized
Weight (重量)	1.248kg/m
Section Area (斷面積)	460.5785mm ²
Second Section Moment (斷面2次 Moment)	lx=4.2x10cm ⁴ ly=4.1x10cm ⁴
Specification (仕様)	4,000mm / 6,000mm
Color (色相)	Silver, Black
Application (用途)	Prevention of Foreign Material Machine Structure Frame, Work Table, Machine Cover (제작 후 이물질 유입방지 타입 기계구조물, 작업대, 기계커버)

CAD Drawing

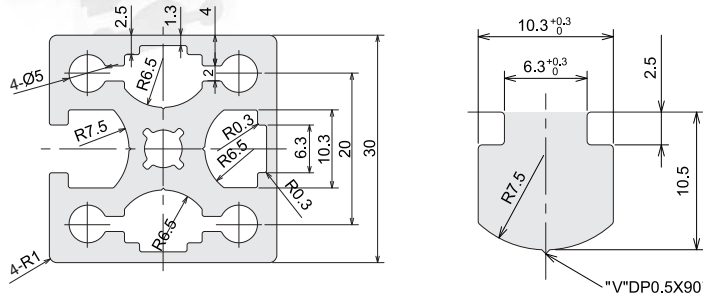

PROFILE



DCF 3060-1 30 X 60

ORDER NUMBER **DY 5135**

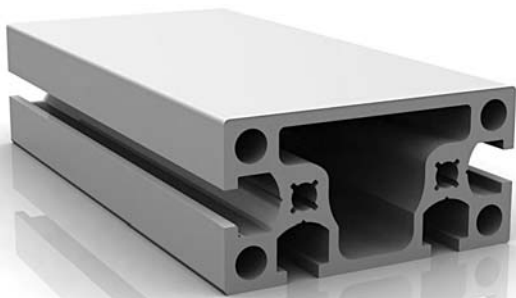

Technical Data (技術 Data)

Material (材質)	A6063-T5
Surface Processing (表面處理)	Anodized
Weight (重量)	1.844kg/m
Section Area (斷面積)	680.3062mm ²
Second Section Moment (斷面2次 Moment)	lx=6.9x10cm ⁴ ly=25.97x10cm ⁴
Specification (仕様)	4,000mm / 6,000mm
Color (色相)	Silver, Black
Application (用途)	Prevention of Foreign Material Machine Structure Frame, Work Table, Machine Cover (제작 후 이물질 유입방지 타입 기계구조물, 작업대, 기계커버)

CAD Drawing

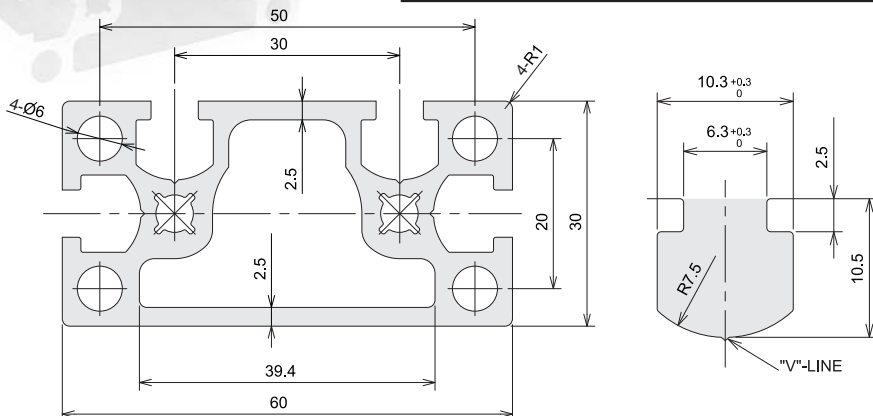

PROFILE



DCF 3060-2 30 X 60

ORDER NUMBER **DY 5136**

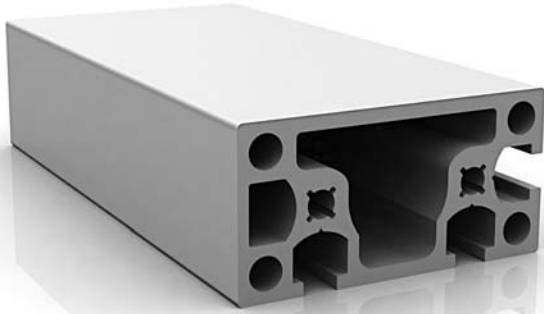

Technical Data (技術 Data)

Material (材質)	A6063-T5
Surface Processing (表面處理)	Anodized
Weight (重量)	1.874kg/m
Section Area (斷面積)	691.3728mm ²
Second Section Monent (斷面2次 Moment)	$I_x=6.9 \times 10 \text{cm}^4$ $I_y=26.9 \times 10 \text{cm}^4$
Specification (仕様)	4,000mm / 6,000mm
Color (色相)	Silver, Black
Application (用途)	Prevention of Foreign Material Machine Structure Frame, Work Table, Machine Cover (제작 후 이물질 유입방지 타입, 기계구조물, 작업대, 기계커버)

CAD Drawing

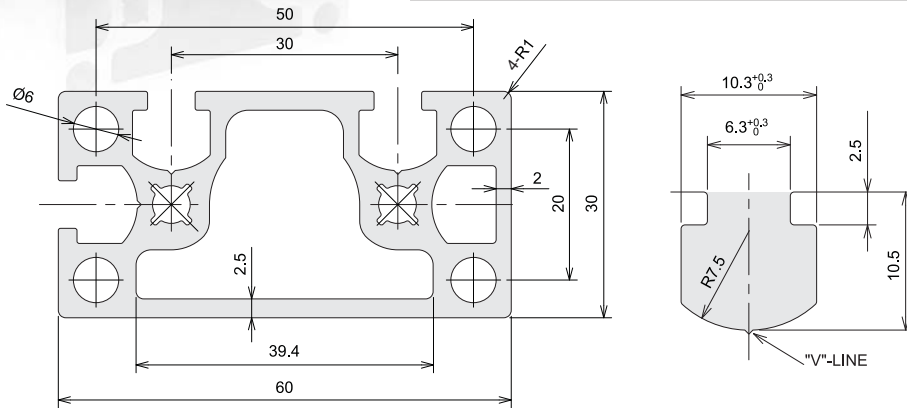

PROFILE



SDNF 3060-51 30 X 60

ORDER NUMBER **DY 5149**

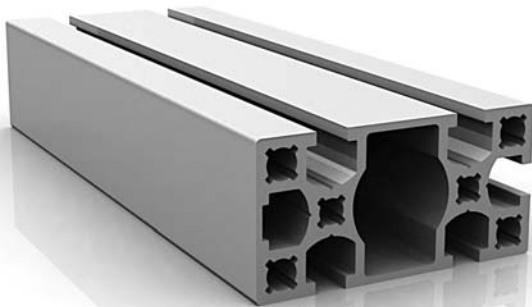

Technical Data (技術 Data)

Material (材質)	A6063-T5
Surface Processing (表面處理)	Anodized
Weight (重量)	1.612kg/m
Section Area (斷面積)	594.8211mm ²
Second Section Monent (斷面2次 Moment)	$I_x=5.6 \times 10 \text{cm}^4$ $I_y=23.8 \times 10 \text{cm}^4$
Specification (仕様)	4,000mm / 6,000mm
Color (色相)	Silver, Black
Application (用途)	Prevention of Foreign Material Machine Structure Frame, Work Table, Machine Cover (제작 후 이물질 유입방지 타입, 기계구조물, 작업대, 기계커버)

CAD Drawing

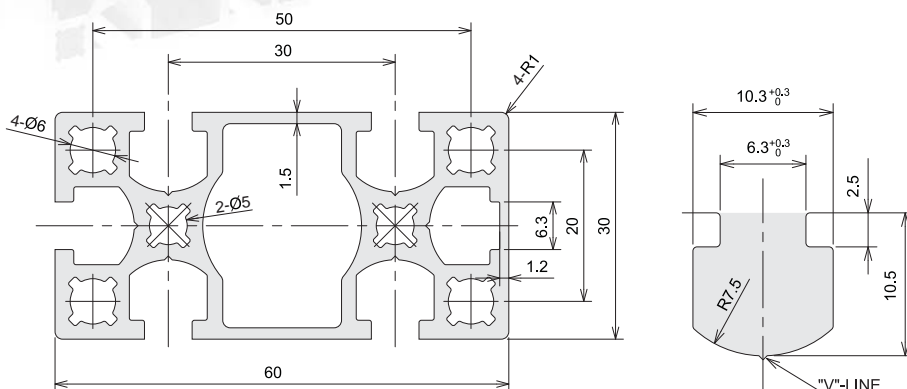

PROFILE



SDNF 3060-1 30 X 60

ORDER NUMBER **DY 5148**



Technical Data (技術 Data)

Material (材質)	A6063-T5
Surface Processing (表面處理)	Anodized
Weight (重量)	1.527kg/m
Section Area (斷面積)	563.4193mm ²
Second Section Moment (斷面2次 Moment)	lx=5.61x10cm ⁴ ly=23.73x10cm ⁴
Specification (仕様)	4,000mm / 6,000mm
Color (色相)	Silver, Black
Application (用途)	Prevention of Foreign Material Machine Structure Frame, Work Table, Machine Cover (제작 후 이물질 유입방지 타입 기계구조물, 작업대, 기계커버)

CAD Drawing

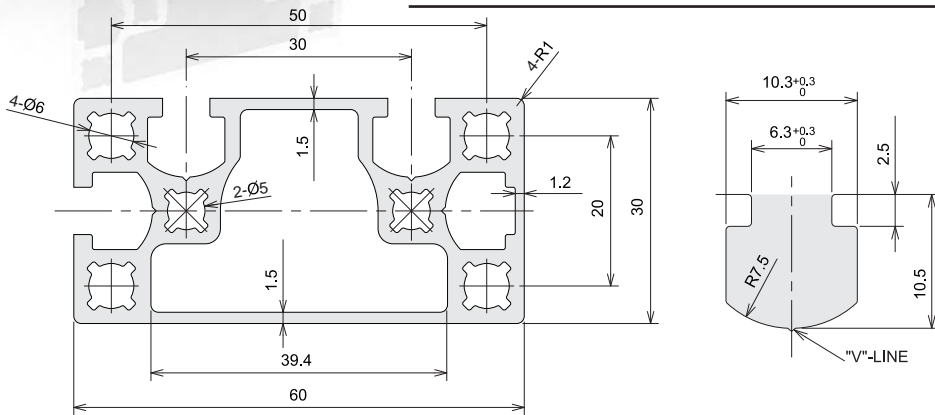

PROFILE



DCF 4040-1 40 X 40

ORDER NUMBER **DY 5036**



Technical Data (技術 Data)

Material (材質)	A6063-T5
Surface Processing (表面處理)	Anodized
Weight (重量)	1.952kg/m
Section Area (斷面積)	720.4045mm ²
Second Section Moment (斷面2次 Moment)	lx=11.4x10cm ⁴ ly=12.0x10cm ⁴
Specification (仕様)	4,000mm / 6,000mm
Color (色相)	Silver, Black
Application (用途)	Prevention of Foreign Material Machine Structure Frame, Work Table, Machine Cover (제작 후 이물질 유입방지 타입 기계구조물, 작업대, 기계커버)

CAD Drawing

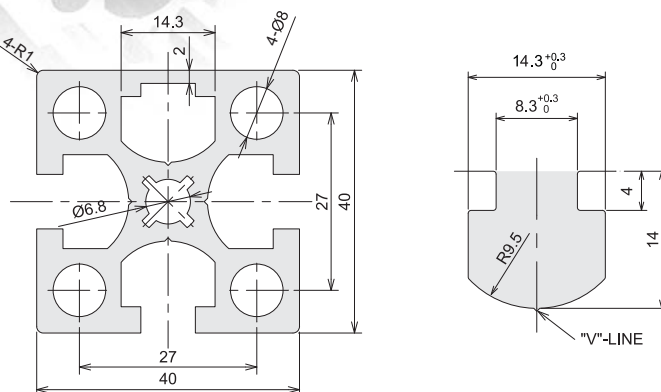

PROFILE



DCF 4040-2 40 X 40

ORDER NUMBER **DY 5129**

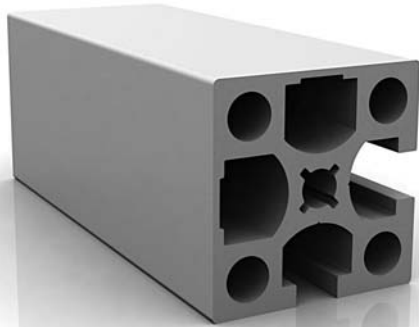

Technical Data (技術 Data)

Material (材質)	A6063-T5
Surface Processing (表面處理)	Anodized
Weight (重量)	1.924kg/m
Section Area (斷面積)	710.0072mm ²
Second Section Monent (斷面2次 Moment)	lx=11.5x10cm ⁴ ly=11.5x10cm ⁴
Specification (仕様)	4,000mm / 6,000mm
Color (色相)	Silver, Black
Application (用途)	Prevention of Foreign Material Machine Structure Frame, Work Table, Machine Cover (제작 후 이물질 유입방지 타입, 기계구조물, 작업대, 기계커버)

CAD Drawing

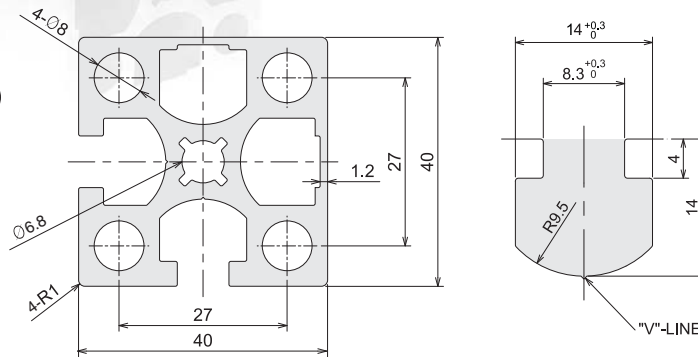

PROFILE



DCNF 4040-1 40 X 40

ORDER NUMBER **DY 5143**

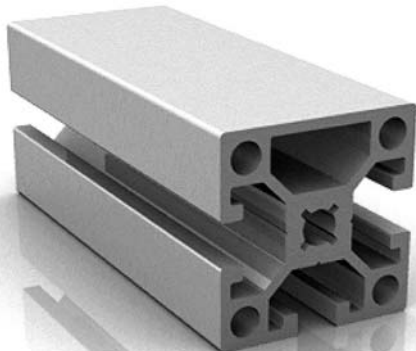

Technical Data (技術 Data)

Material (材質)	A6063-T5
Surface Processing (表面處理)	Anodized
Weight (重量)	1.687kg/m
Section Area (斷面積)	622.3421mm ²
Second Section Monent (斷面2次 Moment)	lx=10.2x10cm ⁴ ly=9.95x10cm ⁴
Specification (仕様)	4,000mm / 6,000mm
Color (色相)	Silver, Black
Application (用途)	Prevention of Foreign Material Machine Structure Frame, Work Table, Machine Cover (제작 후 이물질 유입방지 타입, 기계구조물, 작업대, 기계커버)

CAD Drawing

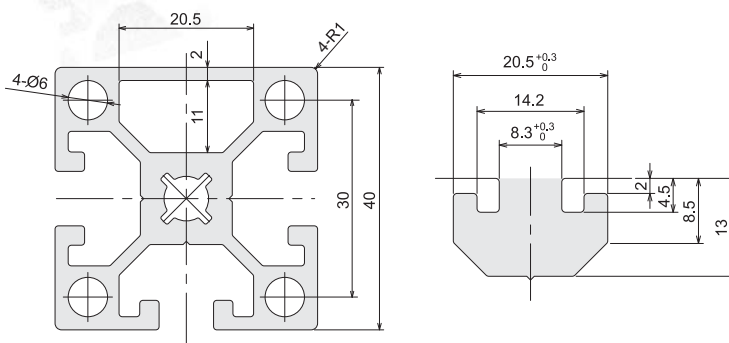

PROFILE



DCNF 4040-2 40 X 40

ORDER NUMBER **DY 5128**

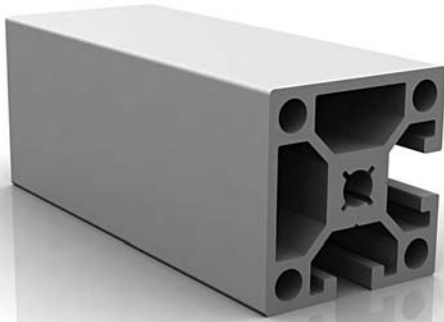

Technical Data (技術 Data)

Material (材質)	A6063-T5
Surface Processing (表面處理)	Anodized
Weight (重量)	1.693kg/m
Section Area (斷面積)	624.6567mm ²
Second Section Moment (斷面2次 Moment)	lx=10.1x10cm ⁴ ly=10.1x10cm ⁴
Specification (仕様)	4,000mm / 6,000mm
Color (色相)	Silver, Black
Application (用途)	Prevention of Foreign Material Machine Structure Frame, Work Table, Machine Cover (제작 후 이물질 유입방지 타입 기계구조물, 작업대, 기계커버)

CAD Drawing

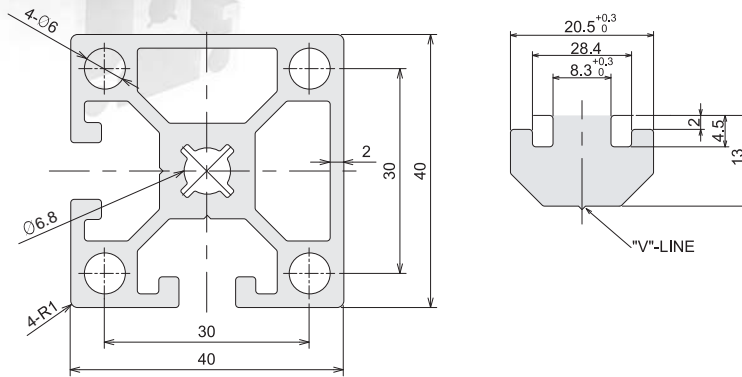

PROFILE



DCNF 4040-L2 40 X 40

ORDER NUMBER **DY 5179**



Technical Data (技術 Data)

Material (材質)	A6063-T5
Surface Processing (表面處理)	Anodized
Weight (重量)	1.685kg/m
Section Area (斷面積)	621.5705mm ²
Second Section Moment (斷面2次 Moment)	lx=9.91x10cm ⁴ ly=10.37x10cm ⁴
Specification (仕様)	4,000mm / 6,000mm
Color (色相)	Silver, Black
Application (用途)	Prevention of Foreign Material Machine Structure Frame, Work Table, Machine Cover (제작 후 이물질 유입방지 타입 기계구조물, 작업대, 기계커버)

CAD Drawing

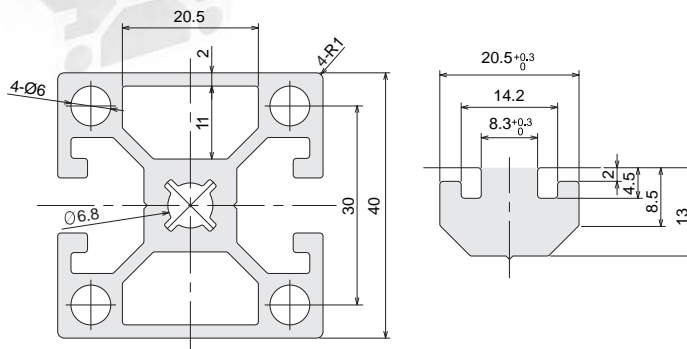

PROFILE



DCF 4080-1 40 X 80

ORDER NUMBER **DY 5132**

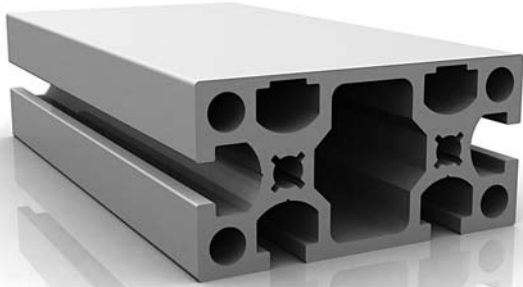

Technical Data (技術 Data)

Material (材質)	A6063-T5
Surface Processing (表面處理)	Anodized
Weight (重量)	3.321kg/m
Section Area (斷面積)	1,225.4919mm ²
Second Section Monent (斷面2次 Moment)	lx=21.1x10cm ⁴ ly=81x10cm ⁴
Specification (仕様)	4,000mm / 6,000mm
Color (色相)	Silver, Black
Application (用途)	Prevention of Foreign Material Machine Structure Frame, Work Table, Machine Cover (제작 후 이물질 유입방지 타입, 기계구조물, 작업대 기계커버)

CAD Drawing

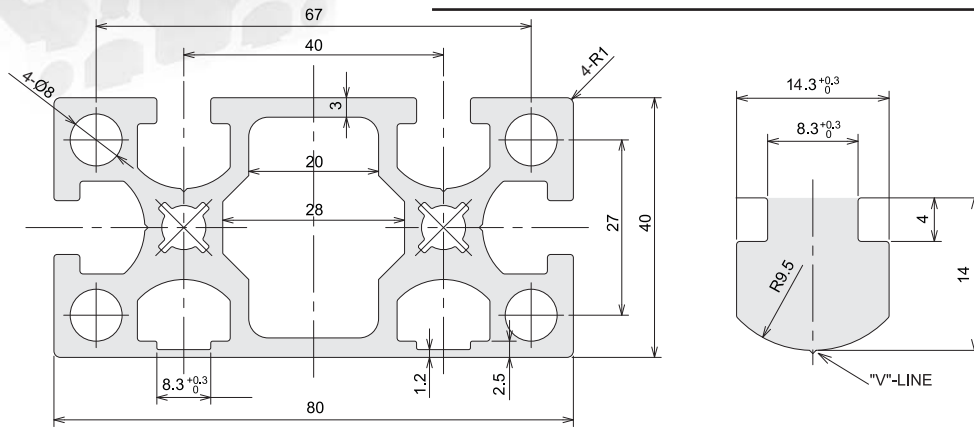

PROFILE



DCF 4080-L2 40 X 80

ORDER NUMBER **DY 5182**



Technical Data (技術 Data)

Material (材質)	A6063-T5
Surface Processing (表面處理)	Anodized
Weight (重量)	3.423kg/m
Section Area (斷面積)	1,263.1355mm ²
Second Section Monent (斷面2次 Moment)	lx=23.47x10cm ⁴ ly=78.34x10cm ⁴
Specification (仕様)	4,000mm / 6,000mm
Color (色相)	Silver, Black
Application (用途)	Prevention of Foreign Material Machine Structure Frame, Work Table, Machine Cover (제작 후 이물질 유입방지 타입, 기계구조물, 작업대 기계커버)

CAD Drawing

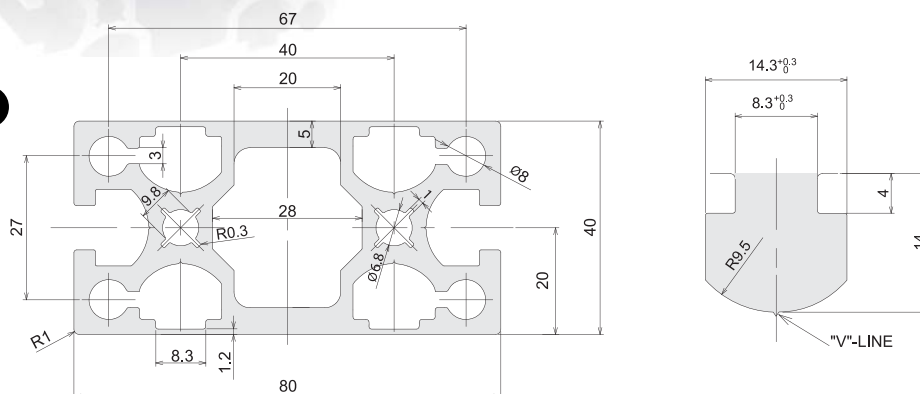

PROFILE



DCF 4080-2 40 X 80

ORDER NUMBER **DY 5131**

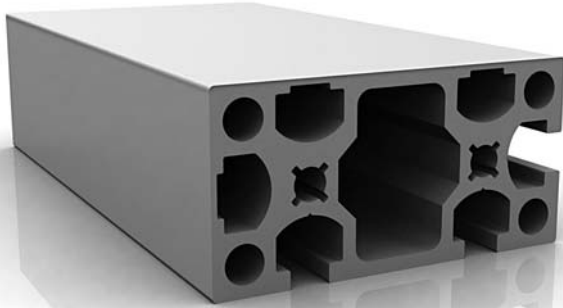

Technical Data (技術 Data)

Material (材質)	A6063-T5
Surface Processing (表面處理)	Anodized
Weight (重量)	3.402kg/m
Section Area (斷面積)	1,255.4372mm ²
Second Section Moment (斷面2次 Moment)	lx=21.12x10cm ⁴ ly=83.55x10cm ⁴
Specification (仕様)	4,000mm / 6,000mm
Color (色相)	Silver, Black
Application (用途)	Prevention of Foreign Material Machine Structure Frame, Work Table, Machine Cover (제작 후 이물질 유입방지 타입 기계구조물, 작업대, 기계커버)

CAD Drawing

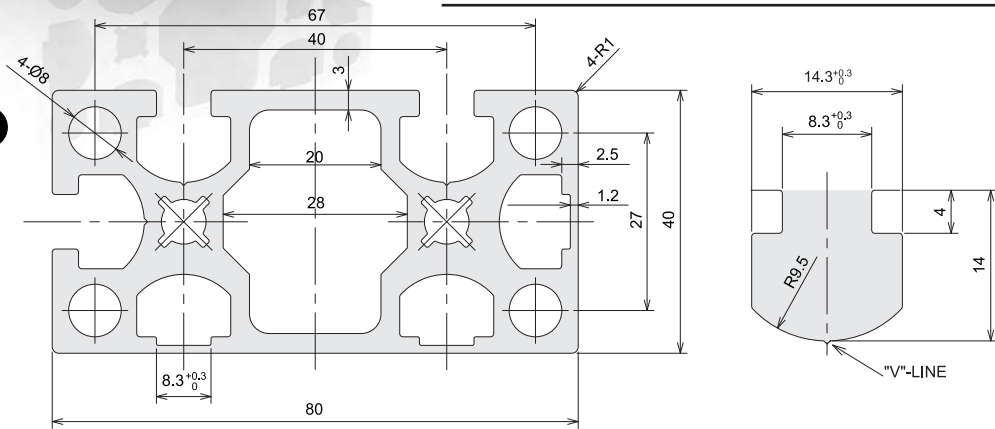

PROFILE



DCNF 4080-1 40 X 80

ORDER NUMBER **DY 5134**



Technical Data (技術 Data)

Material (材質)	A6063-T5
Surface Processing (表面處理)	Anodized
Weight (重量)	2.729kg/m
Section Area (斷面積)	1,007.1053mm ²
Second Section Moment (斷面2次 Moment)	lx=17.7x10cm ⁴ ly=68.4x10cm ⁴
Specification (仕様)	4,000mm / 6,000mm
Color (色相)	Silver, Black
Application (用途)	Prevention of Foreign Material Machine Structure Frame, Work Table, Machine Cover (제작 후 이물질 유입방지 타입 기계구조물, 작업대, 기계커버)

CAD Drawing

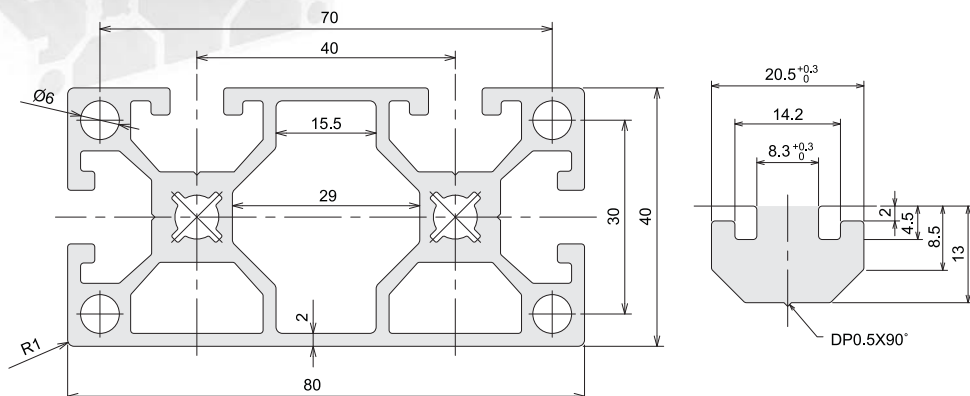

PROFILE



DCNF 4080-2 40 X 80

ORDER NUMBER **DY 5133**

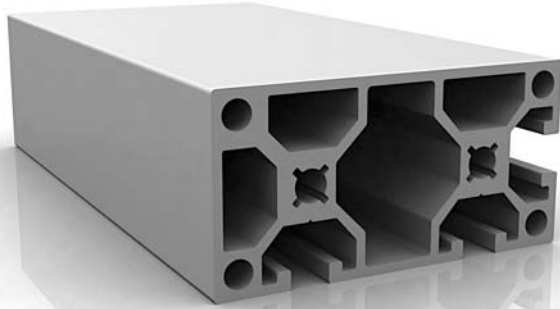

Technical Data (技術 Data)

Material (材質)	A6063-T5
Surface Processing (表面處理)	Anodized
Weight (重量)	2.817kg/m
Section Area (斷面積)	1,039.3508mm ²
Second Section Moment (斷面2次 Moment)	$I_x=17.9 \times 10 \text{cm}^4$ $I_y=71.9 \times 10 \text{cm}^4$
Specification (仕様)	4,000mm / 6,000mm
Color (色相)	Silver, Black
Application (用途)	Prevention of Foreign Material Machine Structure Frame, Work Table, Machine Cover (제작 후 이물질 유입방지 타입, 기계구조물, 작업대 기계커버)

CAD Drawing

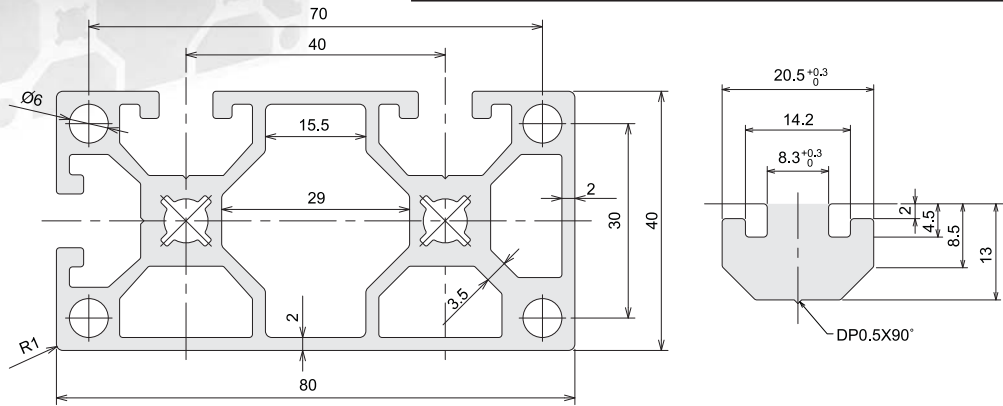

PROFILE



DCNF 4080-L1 40 X 80

ORDER NUMBER **DY 5180**

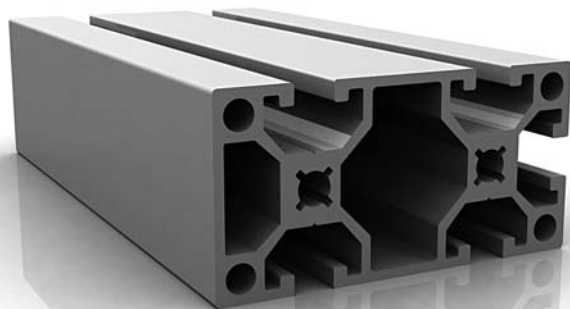

Technical Data (技術 Data)

Material (材質)	A6063-T5
Surface Processing (表面處理)	Anodized
Weight (重量)	2.718kg/m
Section Area (斷面積)	1,003.0217mm ²
Second Section Moment (斷面2次 Moment)	$I_x=17.16 \times 10 \text{cm}^4$ $I_y=68.96 \times 10 \text{cm}^4$
Specification (仕様)	4,000mm / 6,000mm
Color (色相)	Silver, Black
Application (用途)	Prevention of Foreign Material Machine Structure Frame, Work Table, Machine Cover (제작 후 이물질 유입방지 타입, 기계구조물, 작업대 기계커버)

CAD Drawing

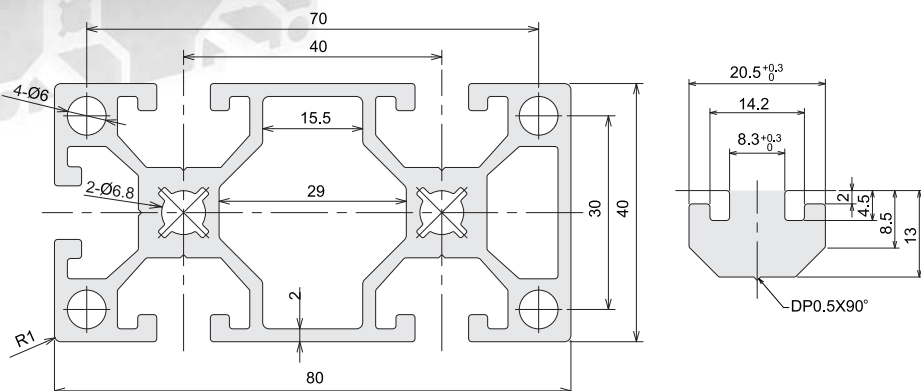

PROFILE



DCNF 4080-L2 40 X 80

ORDER NUMBER **DY 5152**

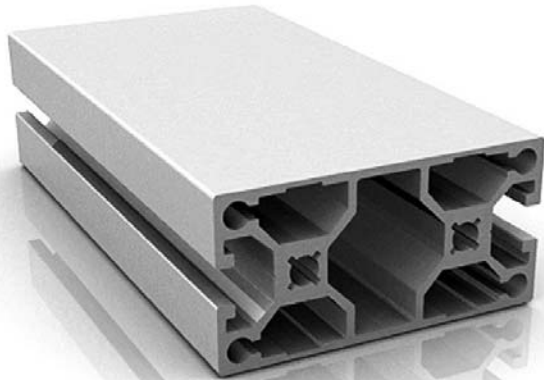

CAD Drawing

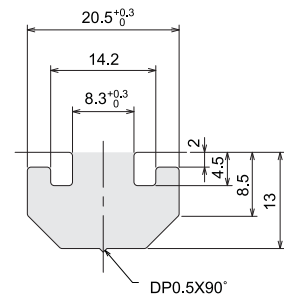
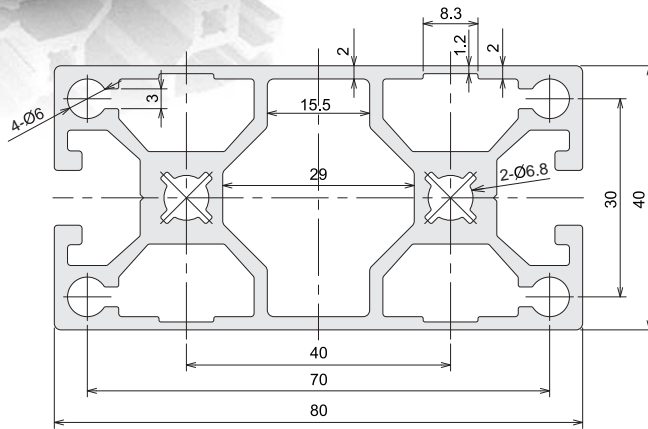

Technical Data (技術 Data)

Material (材質)	A6063-T5
Surface Processing (表面處理)	Anodized
Weight (重量)	2.618kg/m
Section Area (斷面積)	965.9744mm ²
Second Section Monent (斷面2次 Moment)	lx=16.7x10cm ⁴ ly=65.4x10cm ⁴
Specification (仕様)	4,000mm / 6,000mm
Color (色相)	Silver, Black
Application (用途)	Prevention of Foreign Material Machine Structure Frame, Work Table, Machine Cover (제작 후 이물질 유입방지 타입 기계구조물, 작업대, 기계커버)

PROFILE



DCF 6060-1 60 X 60

ORDER NUMBER **DY 5157**

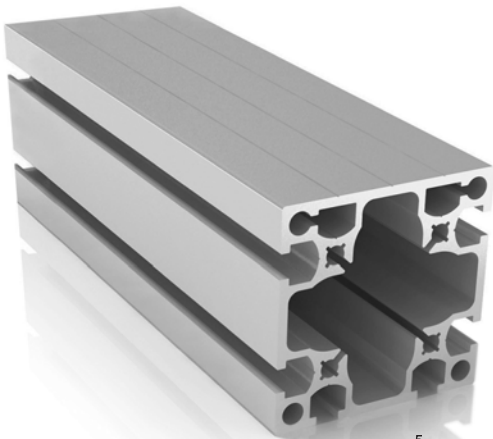

CAD Drawing

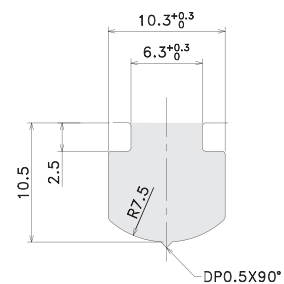
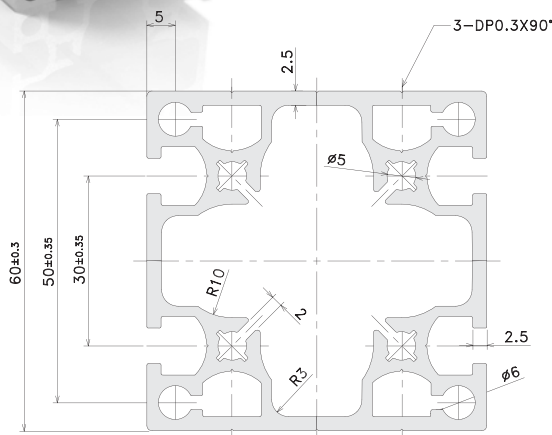

Technical Data (技術 Data)

Material (材質)	A6063-T5
Surface Processing (表面處理)	Anodized
Weight (重量)	2.705kg/m
Section Area (斷面積)	998.1327mm ²
Second Section Monent (斷面2次 Moment)	lx=42.2x10cm ⁴ ly=43.02x10cm ⁴
Specification (仕様)	4,000mm / 6,000mm
Color (色相)	Silver, Black
Application (用途)	Prevention of Foreign Material Machine Structure Frame, Work Table, Machine Cover (제작 후 이물질 유입방지 타입 기계구조물, 작업대, 기계커버)

PROFILE



DCF 6060-2 60 X 60

ORDER NUMBER **DY 5158**

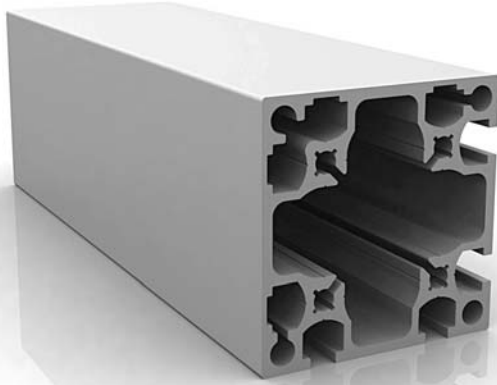

CAD Drawing

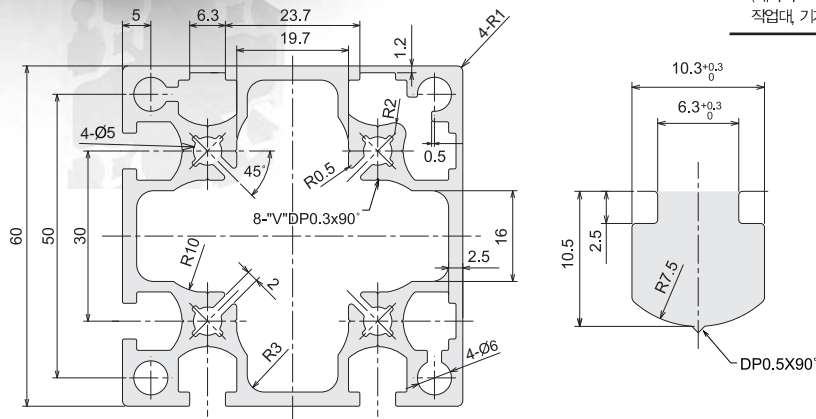

Technical Data (技術 Data)

Material (材質)	A6063-T5
Surface Processing (表面處理)	Anodized
Weight (重量)	2.752kg/m
Section Area (斷面積)	1,015.5071mm ²
Second Section Monent (斷面2次 Moment)	Ix=41.92x10cm ⁴ Iy=42.64x10cm ⁴
Specification (仕様)	4,000mm / 6,000mm
Color (色相)	Silver, Black
Application (用途)	Prevention of Foreign Material Machine Structure Frame, Work Table, Machine Cover (제작 후 이물질 유입방지 타입, 기계구조물, 작업대 기계커버)

PROFILE



DCF 8080-1 80 X 80

ORDER NUMBER **DY 5171**

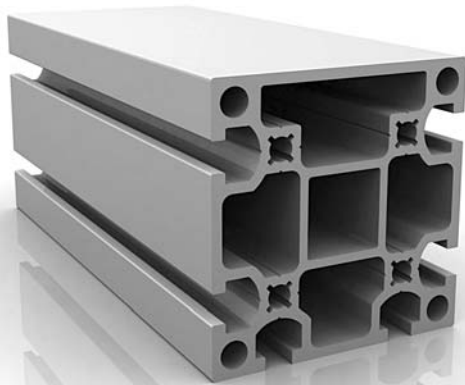

CAD Drawing

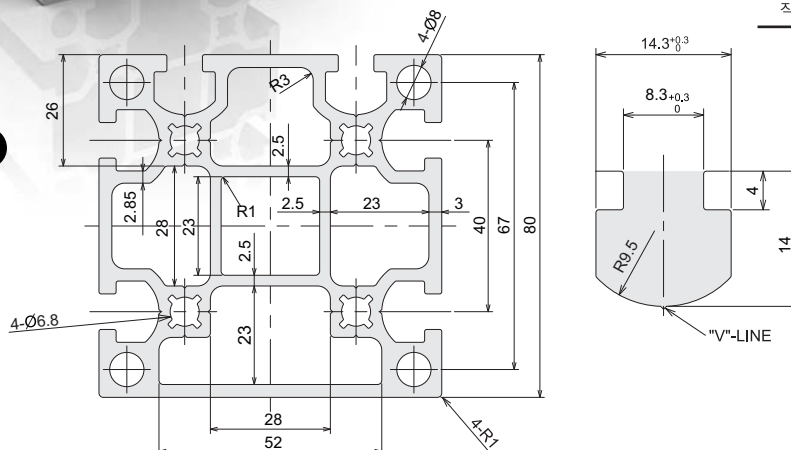

Technical Data (技術 Data)

Material (材質)	A6063-T5
Surface Processing (表面處理)	Anodized
Weight (重量)	5.329kg/m
Section Area (斷面積)	1,966.5635mm ²
Second Section Monent (斷面2次 Moment)	Ix=134.9x10cm ⁴ Iy=136.5x10cm ⁴
Specification (仕様)	4,000mm / 6,000mm
Color (色相)	Silver, Black
Application (用途)	Prevention of Foreign Material Machine Structure Frame, Work Table, Machine Cover (제작 후 이물질 유입방지 타입, 기계구조물, 작업대 기계커버)

PROFILE



DCF 8080-2 80 X 80

ORDER NUMBER **DY 5172**

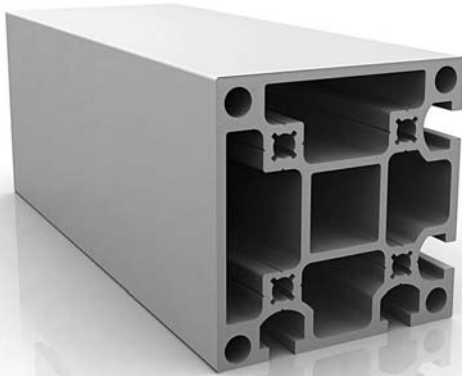

CAD Drawing

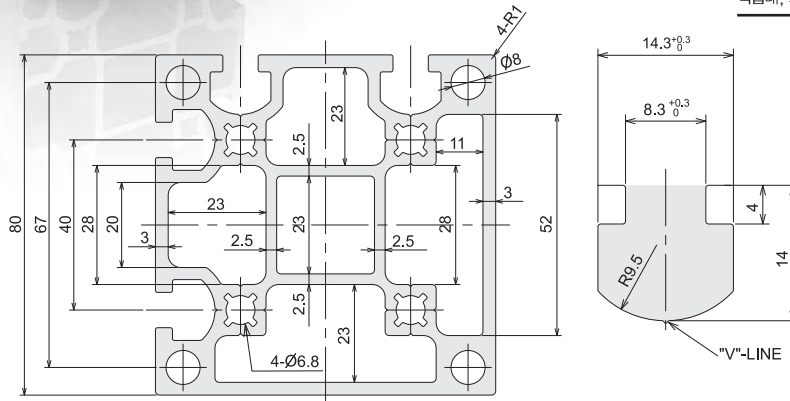

Technical Data (技術 Data)

Material (材質)	A6063-T5
Surface Processing (表面處理)	Anodized
Weight (重量)	5.254kg/m
Section Area (斷面積)	1,938.7387mm ²
Second Section Moment (斷面2次 Moment)	I _x =136.3x10cm ⁴ I _y =136.4x10cm ⁴
Specification (仕様)	4,000mm / 6,000mm
Color (色相)	Silver, Black
Application (用途)	Prevention of Foreign Material Machine Structure Frame, Work Table, Machine Cover (제작 후 이물질 유입방지 타입 기계구조물, 작업대, 기계커버)

PROFILE



DCNF 8080-1 80 X 80

ORDER NUMBER **DY 5173**

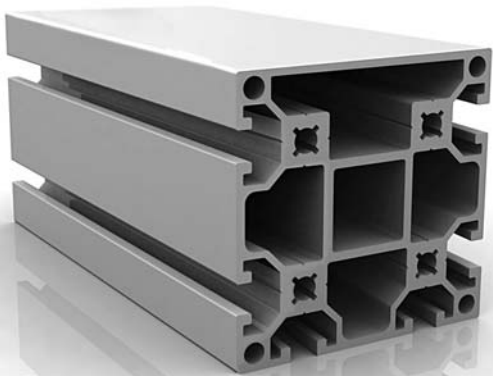

CAD Drawing

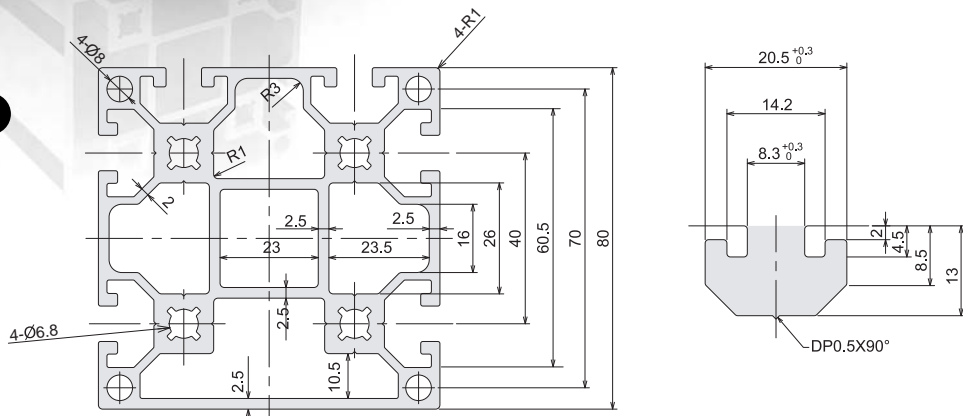

Technical Data (技術 Data)

Material (材質)	A6063-T5
Surface Processing (表面處理)	Anodized
Weight (重量)	5.014kg/m
Section Area (斷面積)	1,850.0126mm ²
Second Section Moment (斷面2次 Moment)	I _x =119.8x10cm ⁴ I _y =121.6x10cm ⁴
Specification (仕様)	4,000mm / 6,000mm
Color (色相)	Silver, Black
Application (用途)	Prevention of Foreign Material Machine Structure Frame, Work Table, Machine Cover (제작 후 이물질 유입방지 타입 기계구조물, 작업대, 기계커버)

PROFILE



DCNF 8080-2 80 X 80

ORDER NUMBER **DY 5174**

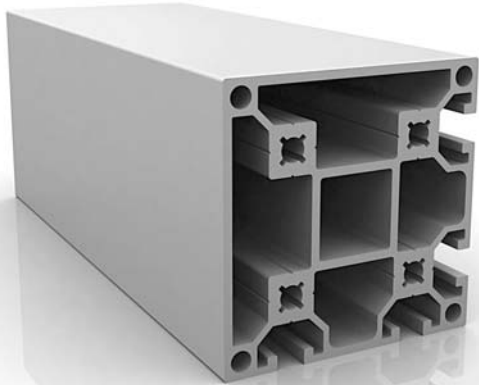

Technical Data (技術 Data)

Material (材質)	A6063-T5
Surface Processing (表面處理)	Anodized
Weight (重量)	4.944kg/m
Section Area (斷面積)	1,824.1858mm ²
Second Section Monent (斷面2次 Moment)	lx=120.3x10cm ⁴ ly=120.4x10cm ⁴
Specification (仕様)	4,000mm / 6,000mm
Color (色相)	Silver, Black
Application (用途)	Prevention of Foreign Material Machine Structure Frame, Work Table, Machine Cover (제작 후 이물질 유입방지 타임, 기계구조물, 작업대, 기계커버)

CAD Drawing

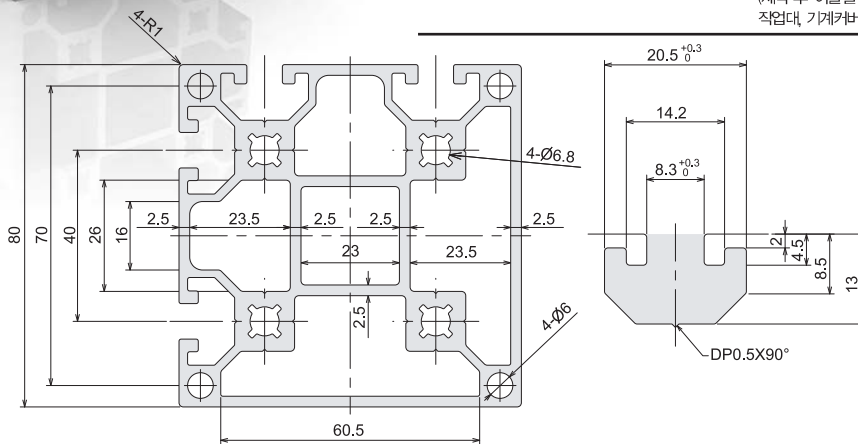

PROFILE



DRF 2020 20 X 20

ORDER NUMBER **DY 5170**

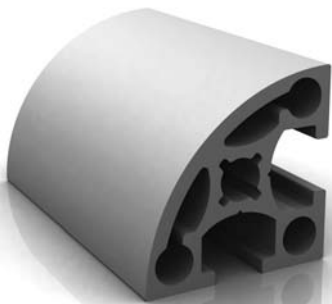

Technical Data (技術 Data)

Material (材質)	A6063-T5
Surface Processing (表面處理)	Anodized
Weight (重量)	0.356/m
Section Area (斷面積)	131.4179mm ²
Second Section Monent (斷面2次 Moment)	lx=0.337x10cm ⁴ ly=0.55x10cm ⁴
Specification (仕様)	4,000mm / 6,000mm
Color (色相)	Silver, Black
Application (用途)	Machine Structure Frame, Work Table, Machine Cover (기계구조물, 작업대, 기계커버)

CAD Drawing

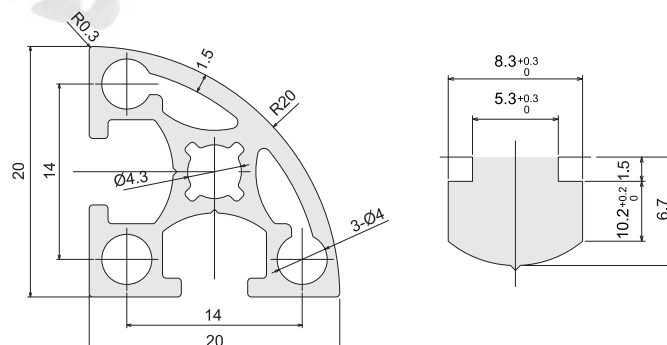

PROFILE



DRF 3030 30 X 30

ORDER NUMBER **DY 5033**



Technical Data (技術 Data)

Material (材質)	A6063-T5
Surface Processing (表面處理)	Anodized
Weight (重量)	0.936kg/m
Section Area (斷面積)	345.5420mm ²
Second Section Moment (斷面2次 Moment)	lx=1.9x10cm ⁴ ly=3.5x10cm ⁴
Specification (仕様)	4,000mm / 6,000mm
Color (色相)	Silver, Black
Application (用途)	Coner Frame, Machine Structure Frame, Work Table, Machine Cover (코너용 프레임, 기계구조물, 작업대, 기계커버)

CAD Drawing

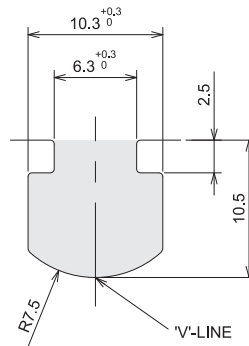
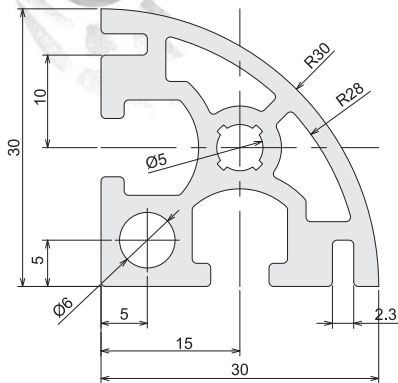

PROFILE



DRF 4040 40 X 40

ORDER NUMBER **DY 5034**

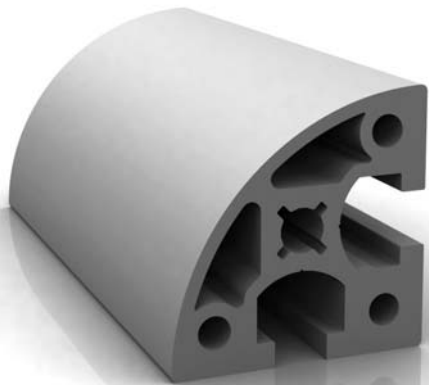

Technical Data (技術 Data)

Material (材質)	A6063-T5
Surface Processing (表面處理)	Anodized
Weight (重量)	1.739kg/m
Section Area (斷面積)	641.8627mm ²
Second Section Moment (斷面2次 Moment)	lx=6.378x10cm ⁴ ly=11.7x10cm ⁴
Specification (仕様)	4,000mm / 6,000mm
Color (色相)	Silver, Black
Application (用途)	Machine Structure Frame, Work Table, Machine Cover (기계구조물, 작업대, 기계커버)

CAD Drawing

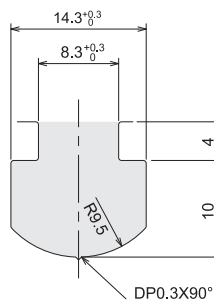
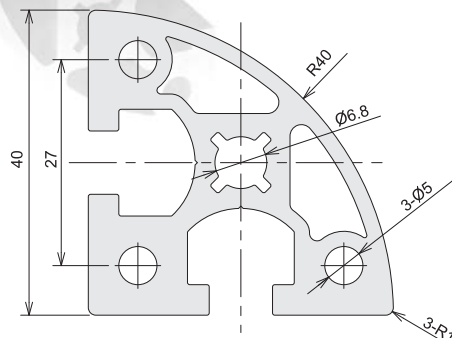

PROFILE



DRF 6060 60 X 60

ORDER NUMBER **DY 5165**

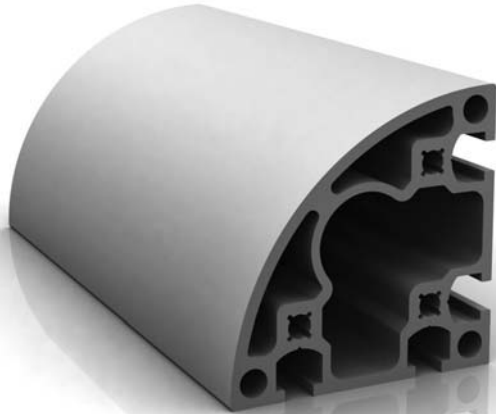

Technical Data (技術 Data)

Material (材質)	A6063-T5
Surface Processing (表面處理)	Anodized
Weight (重量)	2.537kg/m
Section Area (斷面積)	935.9652mm ²
Second Section Monent (斷面2次 Moment)	lx=22.4x10cm ⁴ ly=41.8x10cm ⁴
Specification (仕様)	4,000mm / 6,000mm
Color (色相)	Silver, Black
Application (用途)	Machine Structure Frame, Work Table, Machine Cover (기계구조물, 작업대, 기계커버)

CAD Drawing

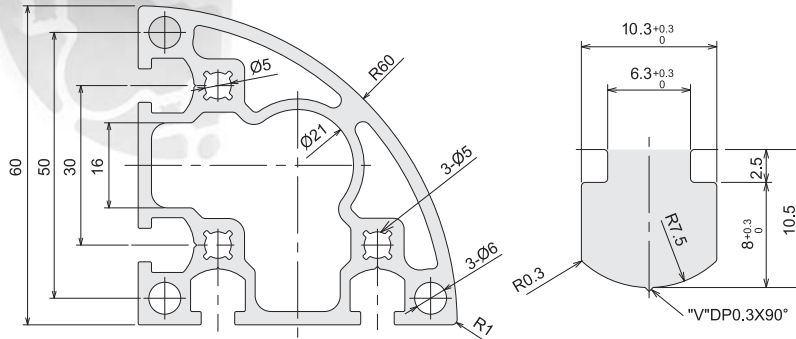

PROFILE



DRF 8080 80 X 80

ORDER NUMBER **DY 5166**

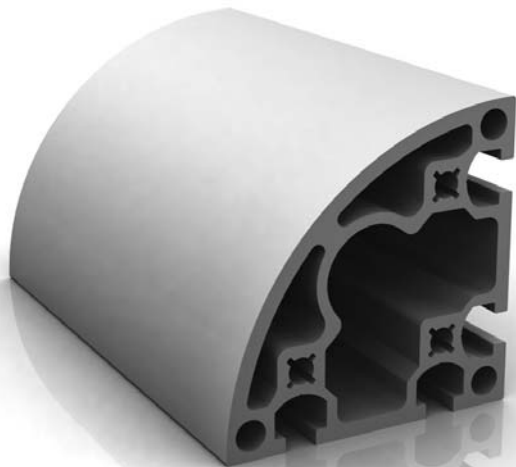

Technical Data (技術 Data)

Material (材質)	A6063-T5
Surface Processing (表面處理)	Anodized
Weight (重量)	4.694kg/m
Section Area (斷面積)	1,732.0221mm ²
Second Section Monent (斷面2次 Moment)	lx=74.495x10cm ⁴ ly=134.69x10cm ⁴
Specification (仕様)	4,000mm / 6,000mm
Color (色相)	Silver, Black
Application (用途)	Machine Structure Frame, Work Table, Machine Cover (기계구조물, 작업대, 기계커버)

CAD Drawing

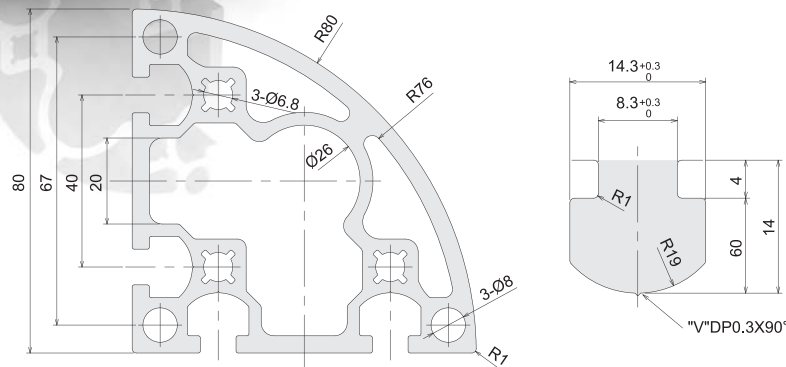

PROFILE



GF 3023 30 X 23

ORDER NUMBER **DY 5038**

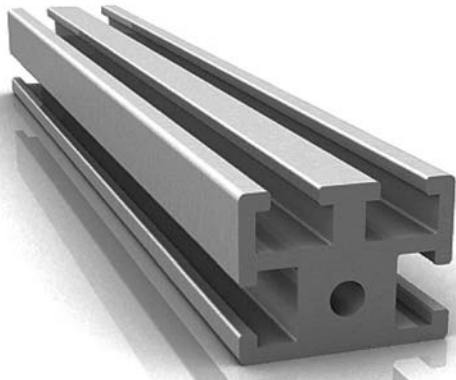

Technical Data (技術 Data)

Material (材質)	A6063-T5
Surface Processing (表面處理)	Anodized
Weight (重量)	1.011kg/m
Section Area (斷面積)	373.0774mm ²
Second Section Moment (斷面2次 Moment)	lx=1.8x10cm ⁴ ly=2.5x10cm ⁴
Specification (仕様)	4,000mm / 6,000mm
Color (色相)	Silver, Black
Application (用途)	Guide Rail for 30mm Series Profile, Sliding Door, Panel Profile, Work Table, Machine Structure Frame, Machine Cover (30mm용 프로파일 가이드 레일, 도어용 프로파일, 판넬 프로파일, 작업대, 기계구조물, 기계커버)

CAD Drawing

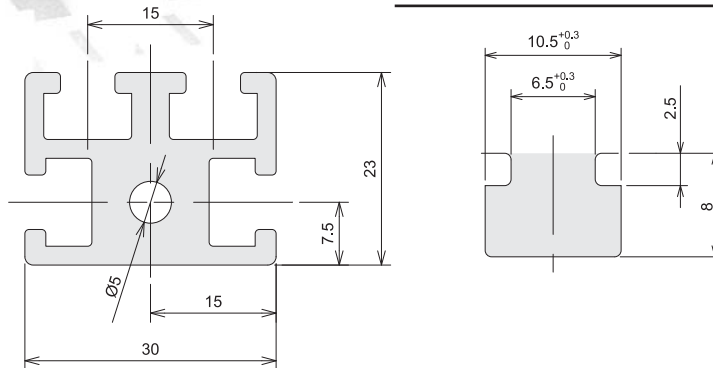

PROFILE



GF 4023 40 X 23

ORDER NUMBER **DY 5039**

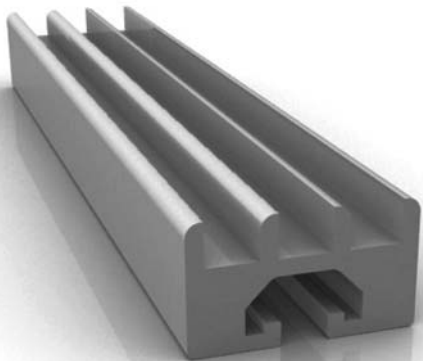

Technical Data (技術 Data)

Material (材質)	A6063-T5
Surface Processing (表面處理)	Anodized
Weight (重量)	1.391kg/m
Section Area (斷面積)	513.3560mm ²
Second Section Moment (斷面2次 Moment)	lx=1.9x10cm ⁴ ly=9.3x10cm ⁴
Specification (仕様)	4,000mm / 6,000mm
Color (色相)	Silver, Black
Application (用途)	Guide Rail for 30mm Series Profile, Sliding Door, Panel Profile, Work Table, Machine Structure Frame, Machine Cover (30mm용 프로파일 가이드 레일, 도어용 프로파일, 판넬 프로파일, 작업대, 기계구조물, 기계커버)

CAD Drawing

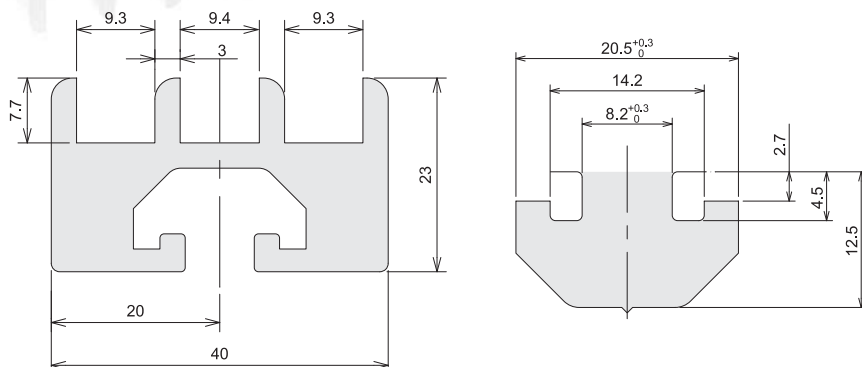

PROFILE



RF 2030 20 X 30

ORDER NUMBER **DY 5153**

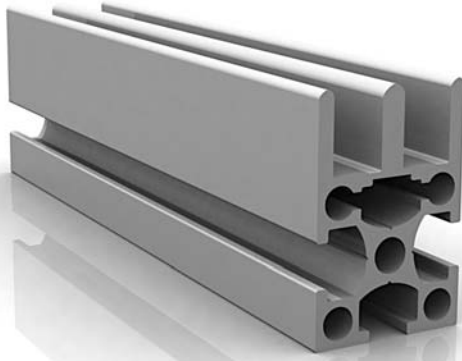

CAD Drawing

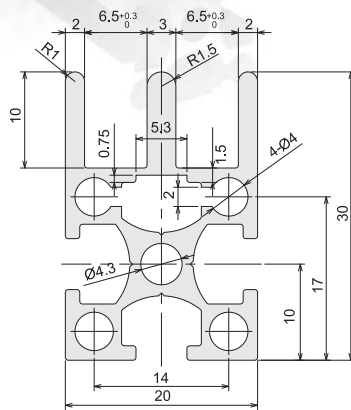

Technical Data (技術 Data)

Material (材質)	A6063-T5
Surface Processing (表面處理)	Anodized
Weight (重量)	0.581kg/m
Section Area (斷面積)	214.5016mm ²
Second Section Monent (斷面2次 Moment)	lx=0.9x10cm ⁴ ly=1.68x10cm ⁴
Specification (仕様)	4,000mm / 6,000mm
Color (色相)	Silver, Black
Application (用途)	Rail for 20mm Series Profile, Sliding Door Profile, Panel Profile (20mm규격 프로파일용 레일, 도어용 프로파일, 판넬용 프로파일)

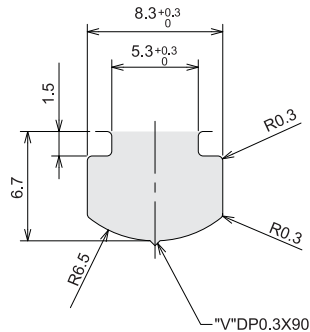

PROFILE



RF 3045 30 X 45

ORDER NUMBER **DY 5040**

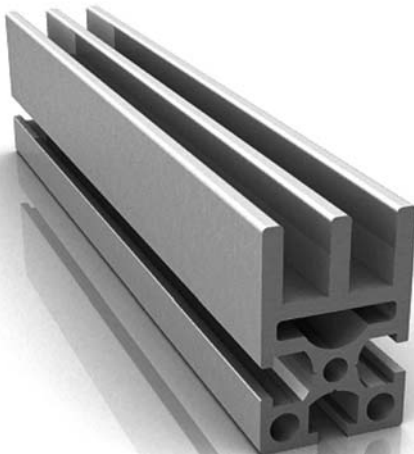

CAD Drawing

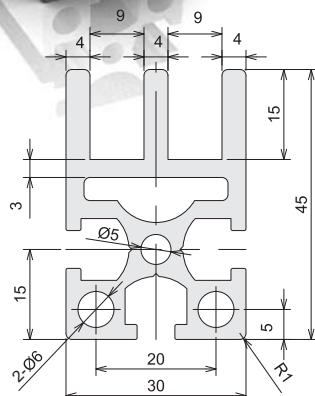

Technical Data (技術 Data)

Material (材質)	A6063-T5
Surface Processing (表面處理)	Anodized
Weight (重量)	1.630kg/m
Section Area (斷面積)	601.6402mm ²
Second Section Monent (斷面2次 Moment)	lx=10.2x10cm ⁴ ly=5.8x10cm ⁴
Specification (仕様)	4,000mm / 6,000mm
Color (色相)	Silver, Black
Application (用途)	Rail for 30mm Series Profile, Sliding Door Profile, Panel Profile (30mm규격 프로파일용 레일, 도어용 프로파일, 판넬용 프로파일)

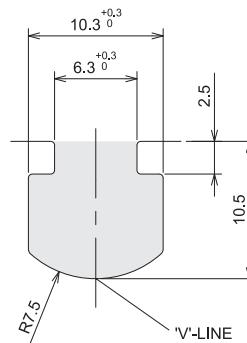

PROFILE



RF 4055 40 X 55

ORDER NUMBER **DY 5041**

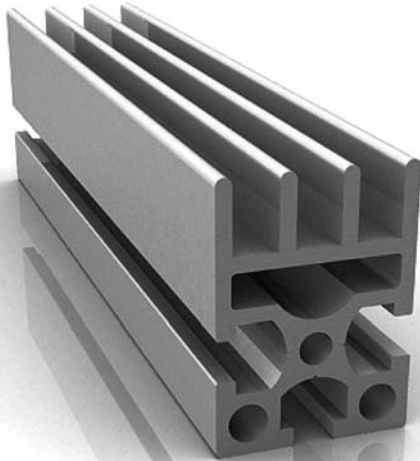

CAD Drawing

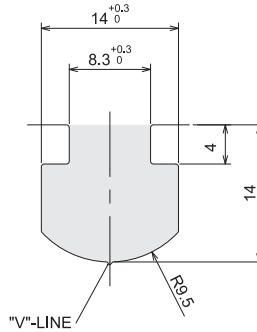
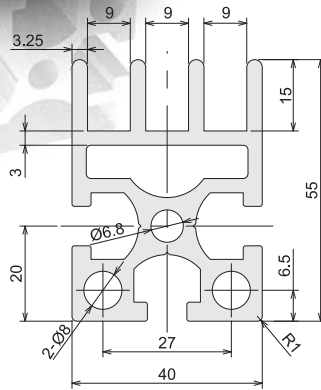

Technical Data (技術 Data)

Material (材質)	A6063-T5
Surface Processing (表面處理)	Anodized
Weight (重量)	2.391kg/m
Section Area (斷面積)	882.4270mm ²
Second Section Moment (斷面2次 Moment)	lx=14.8x10cm ⁴ ly=23.1x10cm ⁴
Specification (仕様)	4,000mm / 6,000mm
Color (色相)	Silver, Black
Application (用途)	Rail for 40mm Series Profile, Sliding Door Profile, Panel Profile 40mm 규격 프로파일용 레일, 도어용 프로파일, 판넬용 프로파일

PROFILE



DY 1483 9 X 32

도어 아크릴 고정용 프로파일 ORDER NUMBER **DY 1483**

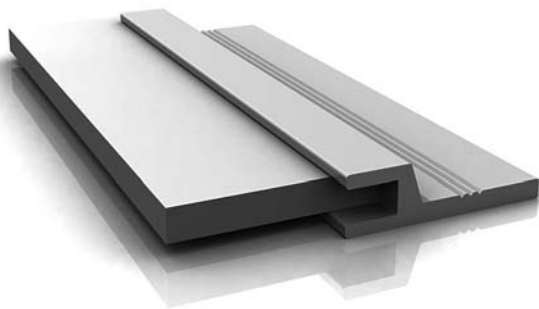

CAD Drawing

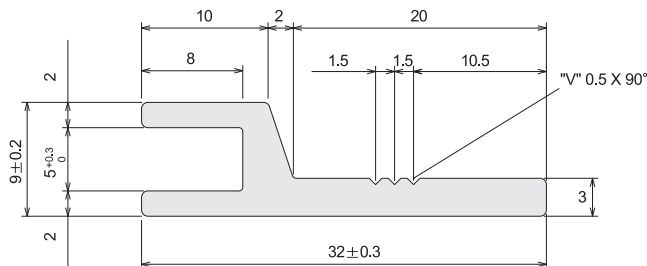

Technical Data (技術 Data)

Material (材質)	A6063-T5
Surface Processing (表面處理)	Anodized
Weight (重量)	0.328kg/m
Section Area (斷面積)	120.9513mm ²
Second Section Moment (斷面2次 Moment)	lx=0.0861x10cm ⁴ ly=1.002x10cm ⁴
Specification (仕様)	4,000mm / 6,000mm
Color (色相)	Silver, Black
Application (用途)	Bracket Profile (브라켓용 프로파일)

PROFILE



DY 3942 15 X 30

도어 아크릴 고정용 프로파일 **ORDER NUMBER DY 3942**

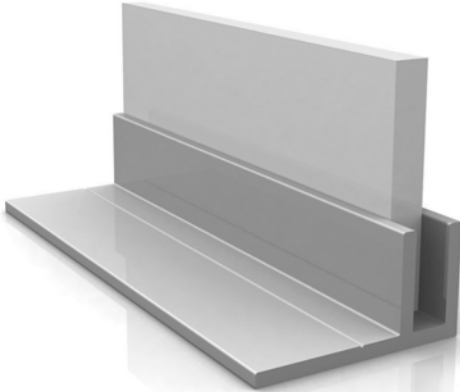

Technical Data (技術 Data)

Material (材質)	A6063-T5
Surface Processing (表面處理)	Anodized
Weight (重量)	0.303kg/m
Section Area (斷面積)	111.8327mm ²
Second Section Moment (斷面2次 Moment)	lx=0.16x10cm ⁴ ly=0.89x10cm ⁴
Specification (仕様)	4,000mm / 6,000mm
Color (色相)	Silver, Black
Application (用途)	Machine Structure Frame, Work Table, Machine Cover (기계구조물, 작업대, 기계커버)

CAD Drawing

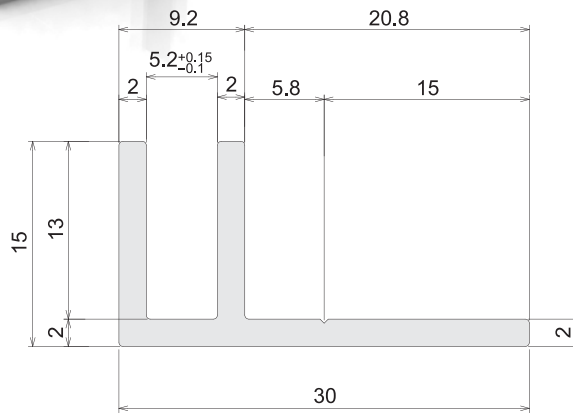

PROFILE



DY 3399 20 X 30

도어 아크릴 고정용 프로파일 **ORDER NUMBER DY 3399**

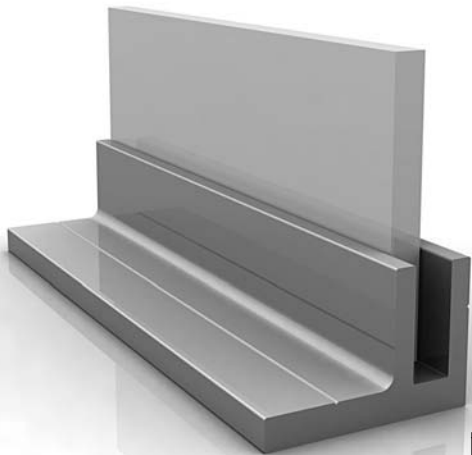

Technical Data (技術 Data)

Material (材質)	A6063-T5
Surface Processing (表面處理)	Anodized
Weight (重量)	0.620kg/m
Section Area (斷面積)	228.5818mm ²
Second Section Moment (斷面2次 Moment)	lx=0.529x10cm ⁴ ly=1.884x10cm ⁴
Specification (仕様)	4,000mm / 6,000mm
Color (色相)	Silver, Black
Application (用途)	Bracket Profile (브라켓용 프로파일)

CAD Drawing

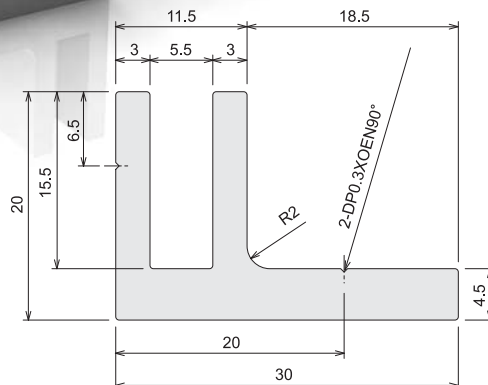

PROFILE



DY 3730 20 X 30

도어 아크릴 고정용 프로파일 **ORDER NUMBER DY 3730**



CAD Drawing

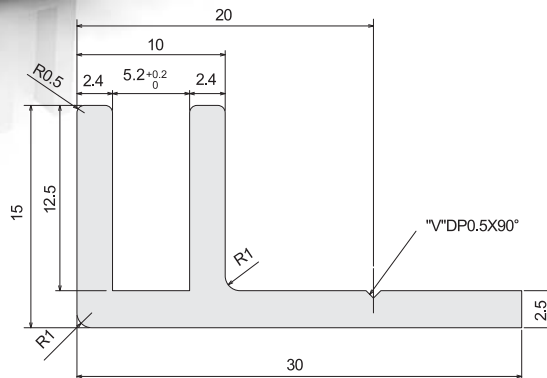

Technical Data (技術 Data)

Material (材質)	A6063-T5
Surface Processing (表面處理)	Anodized
Weight (重量)	0.308kg/m
Section Area (斷面積)	134.5354mm ²
Second Section Moment (斷面2次 Moment)	lx=0.1883x10cm ⁴ ly=1.5083x10cm ⁴
Specification (仕様)	4,000mm / 6,000mm
Color (色相)	Silver, Black
Application (用途)	Bracket Profile (브라켓용 프로파일)

PROFILE



DY 1476 20 X 35

도어 취부용 프로파일 **ORDER NUMBER DY 1476**



CAD Drawing

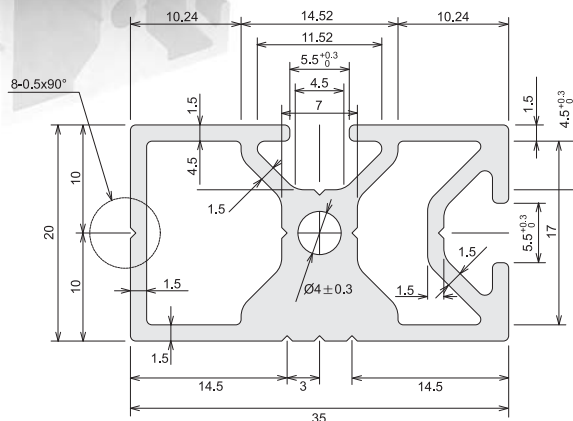

Technical Data (技術 Data)

Material (材質)	A6063-T5
Surface Processing (表面處理)	Anodized
Weight (重量)	0.771kg/m
Section Area (斷面積)	284.5029mm ²
Second Section Moment (斷面2次 Moment)	lx=1.32x10cm ⁴ ly=2.91x10cm ⁴
Specification (仕様)	4,000mm / 6,000mm
Color (色相)	Silver, Black
Application (用途)	Door frame for Automation Equipment (자동화 장비 도어용)

PROFILE



DY 1477 20 X 40

ORDER NUMBER **DY 1477**

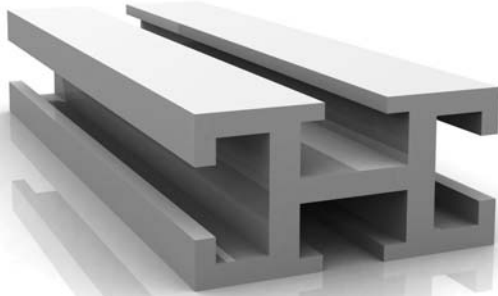

Technical Data (技術 Data)

Material (材質)	A6063-T5
Surface Processing (表面處理)	Anodized
Weight (重量)	0.960kg/m
Section Area (斷面積)	354.1854mm ²
Second Section Monent (斷面2次 Moment)	lx=1.5724x10cm ⁴ ly=5.0344x10cm ⁴
Specification (仕様)	4,000mm / 6,000mm
Color (色相)	Silver, Black
Application (用途)	Door frame for Automation Equipment (자동화 장비 도어용)

CAD Drawing

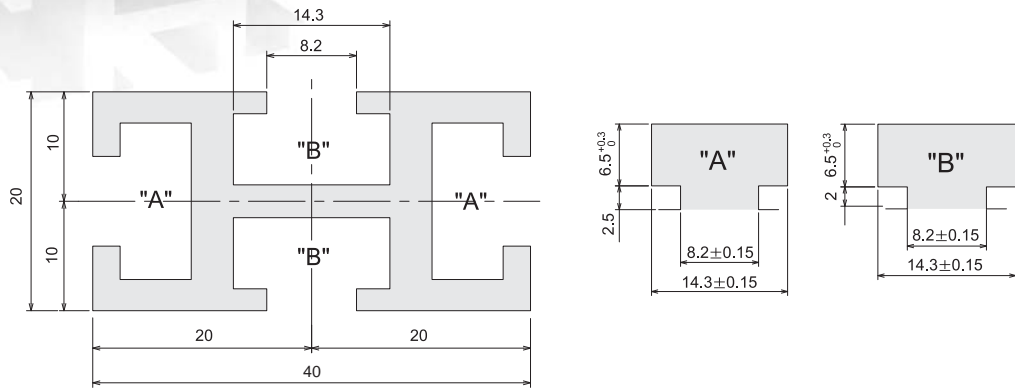

PROFILE



DY 1723 20 X 35

ORDER NUMBER **DY 1723**

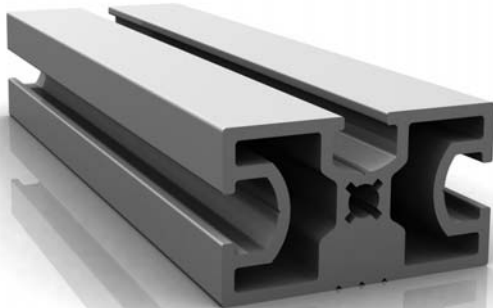

Technical Data (技術 Data)

Material (材質)	A6063-T5
Surface Processing (表面處理)	Anodized
Weight (重量)	0.802kg/m
Section Area (斷面積)	295.9848mm ²
Second Section Monent (斷面2次 Moment)	lx=1.29x10cm ⁴ ly=3.01x10cm ⁴
Specification (仕様)	4,000mm / 6,000mm
Color (色相)	Silver, Black
Application (用途)	Door Frame, Machine Structure Frame, Work Table, Machine Cover (도어 프레임, 기계구조물, 작업대, 기계커버)

CAD Drawing

